

REMORAN WAVE 3



OPERATING MANUAL

Version 0.9
Last updated on 27. Apr 2022

SISÄLLYS

Sisällys	4
1. Safety measures	6
1.1 Electrical safety	6
1.2 Installation safety measures	6
1.3 Restrictions concerning operation and the operating environment	7
1.4 Safety measures concerning operation and the operating environment	7
2. Product information	8
2.1 General description and operating principle	8
2.2 Contents of the sales package	8
2.2.1 Hydrogenerator	9
2.2.2 Charger	10
3. Storage and transport	11
4. Mounting	11
4.1 Summary of the mounting steps	12
4.2 Fastening the mounting rail to the boat	13
4.3 Mounting and dismounting the turbine	15
4.4 Installing the charger	16
4.4.1 Installation location considerations:	16
4.4.2 Installing the cable feedthrough	16
4.4.3 Using extended generator cables	17
4.4.4 Connecting the generator cables to the charger	18
4.4.5 Connecting the charging wires to the charger	18
4.4.6 Circuit diagram	20
5 Operating the hydrogenerator	21
5.1 Before operation	21
5.1.1 Adjusting the height of the outboard unit	21
5.1.2 Mounting the outboard unit on the rail	22
5.1.3 Adjusting the angle of the outboard unit	23

5.2 During sailing	24
5.3 Dismounting the outboard unit	25
6. Operating the charger	25
6.1 Before operating the charger	25
6.2 Operating the charger	26
6.3 Charger's charging algorithms	26
6.4 Short-circuit of the charger	28
6.5 Backup battery of the charger clock	29
6.6 Charger LED indicators	30
7. Technical specifications	31
7.1 Hydrogenerator outboard unit	31
7.2 Charger	31
7.3 Performance	32
7.4 Protection relay	33
8. Troubleshooting	34
8.1 Outboard unit issues and malfunctions	34
8.2 Charging issues	34
8.3 Bluetooth connection issues	36
9. Maintenance	37
10. Product disposal	38
10.1 Disposal of the hydrogenerator	38
10.2 Disposal of the charger	38
11. Supplies and spare parts	39
12. Warranty	40
13. FAQ	41
14. Declaration of Conformity	42
14.1 Supplier's Declaration of Conformity	
47 CFR § 2.1077 Compliance Information	42
Attachment 1 Product return form	44
Attachment 2 Cooling plate installation guide	45

Thank you
for selecting Remoran™ Wave 3 Hydrogenerator!
Remoran™ Wave 3 Hydrogenerator is a state-
of-the-art product based on Finnish design and
workmanship.

We hope you enjoy your voyage
with Remoran™ Wave 3 Hydrogenerator!

Please read the operating manual in full before
operating the product.
Remoran reserves the right to modify
this document at any time.

1. SAFETY MEASURES

1.1 Electrical safety

When the hydrogenerator operates in a normal manner (the maximum speed is not exceeded), the voltages generated by the generator and the charger will not exceed 120VDC or 50VAC. Thus, the product operates in the extra-low voltage area. Extra-low voltage is considered to be safe for the operator. However, the operator is always responsible for monitoring the functioning of the product and, if needed, disconnecting the charger and the hydrogenerator to prevent hazard and damage.

The charging current causes power loss in the wires, resulting in warming of the wires. Abnormal warming indicates a malfunction in the equipment. If that happens, the operator must immediately discontinue charging (stop the boat) and investigate the cause of the malfunction. In the installation stage, the charging wires of the battery should always be connected last (the generator wires are connected first).



The positive (red, +) charging wire should always be equipped with a circuit breaker (40A).



Verify the polarity of the charging wires (+, -) to ensure you perform the connection correctly. Damage to the charging unit is inevitable if it is installed improperly. For more detailed installation instructions, see section 4.4 Installing the charger.

1.2 Installation safety measures

When determining the location to mount the product in the back of the boat, keep in mind that the outboard unit weighs 7.5 kg. It is important to find an optimal location for mounting the product, since the location has a material impact on performance. If possible, request another person's assistance to ensure that the product is mounted safely. If you mount the product while the boat is afloat, wear the required safety gear (a safety vest, for example).

1.3 Restrictions concerning operation and the operating environment

To prevent product breakdowns, the maximum operating speed of the boat is 15 knots. (Note! The charging unit stores data on the turbine rotation speed and uses this data to calculate the operating speed of the boat.) If the operating speed approaches 15 knots, lift the product up from the water or disconnect the interior connector of the generator cable from the connector of the outboard unit's cable.

For the winter, the outboard unit must be dismantled from the boat and stored in a warm (+5°C) area to prevent it from freezing. Do not operate or store the product at temperatures below 0°C, since any water remaining in its structures may freeze and thus break the product.

1.4 Safety measures concerning operation and the operating environment

- Foreign objects such as seaweed entangled in the generator unit must be removed immediately. Foreign objects (fishnets, fishing line, seaweed) increase friction and considerably increase the force the structures are exposed to.
- Note that in order to operate the product safely, the operator must inspect the product regularly and carry out the required cleaning and maintenance procedures.
- The product should be mounted on the boat in accordance with this manual while observing precision and care.
- Check the outboard unit for any signs of impact or other mechanical forces.
- Check that the charging unit has been installed properly (both in terms of electrical and mechanical requirements) and that it has not been exposed to water.

2. PRODUCT INFORMATION

2.1 General description and operating principle

The hydrogenerator generates electrical energy when the boat is in motion. The turbine of the outboard unit that is installed in the transom on the outside of the boat rotates when the boat is in motion, running the generator located in the lower part of the outboard unit. The generator produces low-voltage three-phase electricity, which is conducted to a charger, installed inside the boat, through a weather-resistant cable and a feedthrough connector. The charger converts the electrical energy to a form feasible for batteries (12V or 24V) and also ensures that the charging sequence of the battery is correct. The Remoran™ Charger 300W supports **Bluetooth® wireless technology** which allows the user to connect the charger to their own smartphone.

2.2 Contents of the sales package

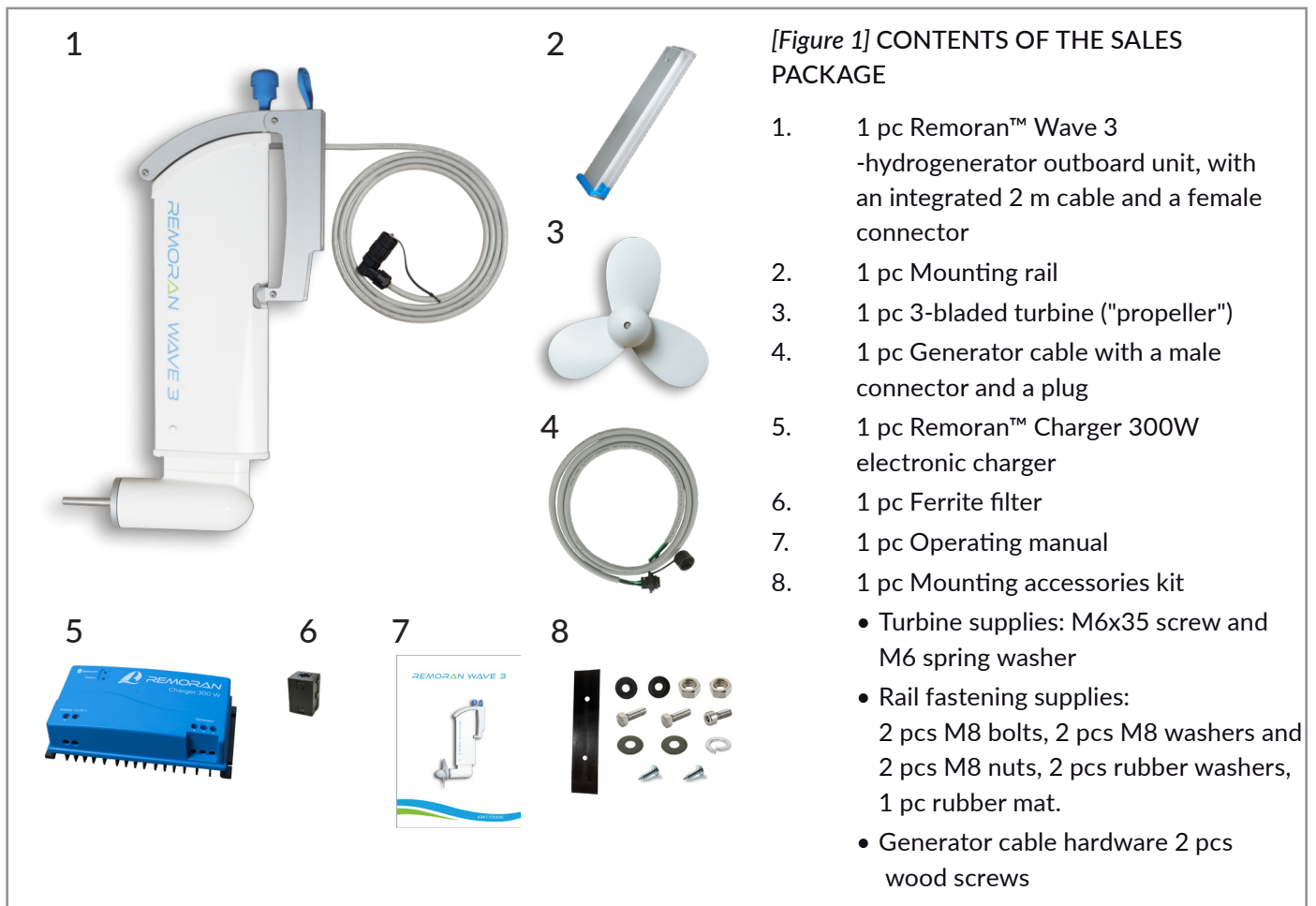

2.2.1 Hydrogenerator

The outboard unit of the hydrogenerator consists of a frame, a telescopic blade and a turbine. The top of the blade is attached to the frame. The top of the frame is equipped with a locking handle that snap-locks the outboard unit to the mounting rail fastened to the boat transom. There is an angle guide extending from the top of the frame, and the angle adjustment knob slides along this guide. The angle adjustment knob locks the blade to the desired position.

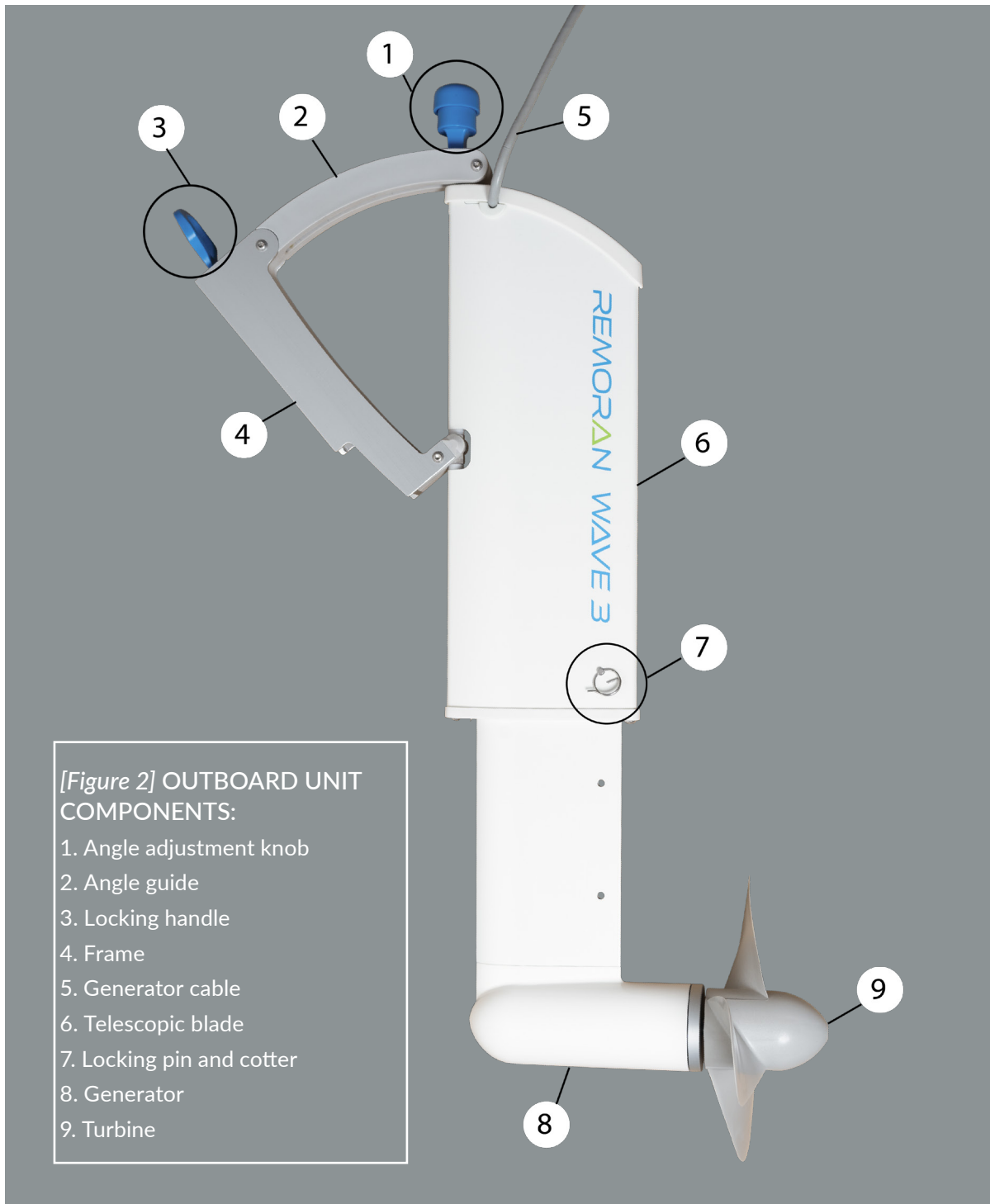

[Figure 2] OUTBOARD UNIT COMPONENTS:

1. Angle adjustment knob
2. Angle guide
3. Locking handle
4. Frame
5. Generator cable
6. Telescopic blade
7. Locking pin and cotter
8. Generator
9. Turbine

2.2.2 Charger

The charger consists of a cooling profile, printed circuit board and a plastic cover equipped with screw terminals for cables as well as the charger status and **Bluetooth** connection indicator lights.

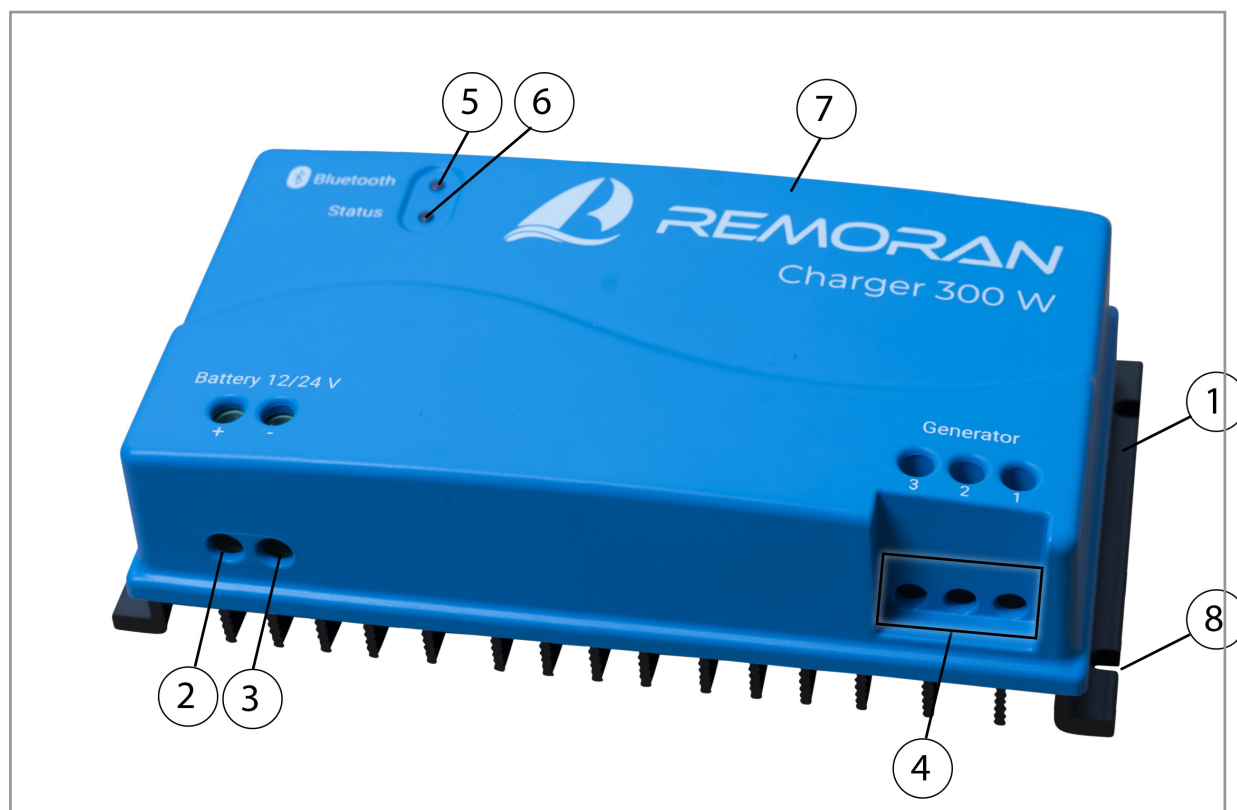

[Figure 3] CHARGER COMPONENTS:

- | | |
|---|--|
| 1. Cooling profile | 5. Bluetooth ® connection indicator |
| 2. Charging wire (pos) | 6. Charger's Status LED indicator |
| 3. Charging wire (neg) | 7. Plastic cover |
| 4. Screw terminals of the generator wires | 8. Fastening slots (4 pcs) |

3. STORAGE AND TRANSPORT

An unused product can also be stored in its sales package in temperatures below 0°C.

After operation, the product must be dried before storage to prevent corrosion. Since it is possible that some moisture remains inside the product, the product should be stored in a warm indoor area through the winter to prevent freezing.

The product should be transported and shipped in its sales package with all original inner packaging supplies in place to prevent damage during transport.

4. MOUNTING

The mounting measures described in this chapter must be carried out before the actual operation of the product. Measures included in the regular operation, such as mounting the generator to the mounting rail, are shown in chapter 5.

The required mounting supplies in addition to those provided in the sales package:

- Sealant approved for marine conditions
- Black and red wire 6–10 mm² (available in the Remoran web store or a corresponding product)
- Circuit breaker 40 A (available in the Remoran web store or a corresponding product)
- Screws 4 pcs for fastening the charger (Ø 4 mm, select the screw length based on the thickness of the base)
- Reinforcement board made of, for example, plywood (a piece of approximately 18 cm x 5 cm). Select the reinforcement board so that the combined thickness of the transom and the reinforcement board is a minimum of 30 mm. The thickness of the reinforcement board also depends on the material of the board and the transom.

Tools:

- Drill and both 8 mm and 22 mm bits.
- Screwdrivers
- Open-end wrench or sleeve, or similar (size: 13 mm)
- Allen key (size: 4 mm)

4.1 Summary of the mounting steps



[Figure 4] Feedthrough connectors installed in the boat

1. The outboard unit is mounted to the boat using a mounting rail. **The rail is installed in the** boat's transom by means of bolts inserted through two holes drilled through the transom. The heads of the bolts settle in the groove in the rail and the fastening nuts are fastened to the bolt ends on the inside of the boat. Seal the holes drilled for the bolts with sealant that is resistant to sunlight and marine conditions. (See section 4.2 Installing the mounting rail on the boat.)
2. **A feedthrough connector must be installed in** the deck of the boat or in the transom near the generator so that the generator cable reaches it (Figure 4). The generator cable portion that remains inside of the boat is integrated in the connector. The connector requires a drilled hole that should be sealed, and the connector is fastened to the deck by means of the wood screws supplied. (See section 4.4.2 Installing the cable feedthrough)
3. **The charger must be installed** inside the boat, and the generator cable and the charging wires from the boat's batteries should be connected to it. Install a 40 A circuit breaker on the red (+) charging wire as near the batteries or main switch as possible. (See section 4.4.4 Connecting the wires to the charger)
4. **The turbine** is supplied unattached and must be mounted on the generator axle before use. (See section 4.3 Mounting and dismounting the turbine)

4.2 Fastening the mounting rail to the boat

Since the outboard unit's angle can be adjusted between 0 and 40 degrees, the rail can usually be fastened directly to the transom of the boat. If the angle of the transom is negative or wider than 40 degrees from the vertical axis, an adapter must be prepared. If needed, contact the manufacturer for further information.

The mounting rail is subjected to considerable mechanical loads. Plan and prepare the fastening of the rail carefully before starting work. The sales package includes acid-resistant M8x50 bolts as well as M8 nuts and M8 washers, 2 pcs of each and 2 pcs of rubber washers and a rubber mat for fastening the rail. The length of the bolts is usually sufficient for the purpose. However, you should use longer bolts, if needed. Drill 8 mm holes.

It is recommended that on the inside of the boat, you use an additional reinforcement board that is slightly larger than the rail so that it provides a sufficient mechanical locking action and spreads the mechanical stress over a larger area. Apply sealant that is resistant to sunlight and marine conditions to the holes drilled through the transom.

Parts required and supplied in the sales package: (or an accessory "Standard rail kit") (Figure 5)

- Mounting rail
- 2 pcs M8x50 bolts
- 2 pcs M8 washers
- 2 pcs M8 nuts
- 2 pcs Rubber washers
- 1 pc Rubber mat

You will also need:

- Reinforcement board (for dimensions, see section 4. Mounting)
- Sealant
- Marking pen
- Drill 8 mm

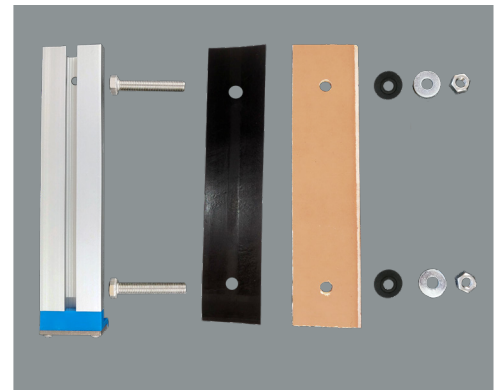

[Figure 5] Components required for fastening the rail (from left to right):

- Mounting rail
- 2 pcs M8x50 bolts
- 1 pc rubber mat
- 1 pc Reinforcement board (not included in the sales package)
- 2 pcs rubber washers
- 2 pcs M8 washers
- 2 pcs M8 nuts

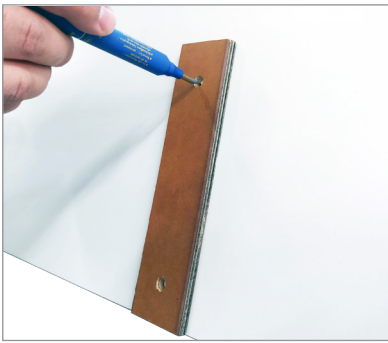

[Figure 6] Mark the locations of the holes with a marker



[Figure 7] Slide the heads of the bolts into the groove in the rail

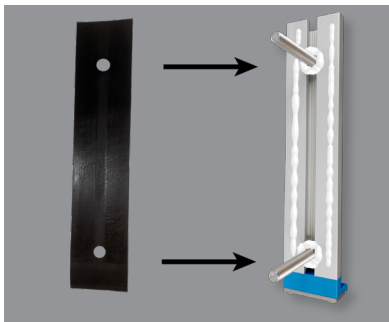

[Figure 8] Place the rubber mat on the rail



[Figure 9] Fit the bolts in the rail into the holes

Selecting the installation location

The rail should be fastened near the bottom edge of the transom or near the additional supporting bulkheads. Select the installation location so that when the outboard unit is mounted on the rail, the turbine remains submerged at all times. We do not recommend installing the rail in the line of the rudder due to the turbulence of the flow. Check that there is sufficient space behind the transom to install the rail and, when needed, the additional reinforcement board. The distance between the holes should be 10–15 cm. Use the reinforcement board as a template and mark the locations of the holes in the transom. (Figure 6). Leave the lower end open at least at a distance equalling the thickness of the bottom. Drill the 8 mm holes in the locations marked in the transom.

Installing the rail in the holes

- Slide the heads of the bolts into the groove in the rail (Figure 7).
- Place the rubber mat on the rail (Figure 8).
- Fit the bolts in the rail into the holes so that the blue plastic end of the rail the faces down (Figure 9).
- Apply sealant to the stems of the bolts and the bottom surface of the rail and the rubber mat.
-
- Press the rail tightly into place so that the sealant keeps it from sliding down before the nuts are tightened.
- You can ensure that the rail stays in place during fastening the bolts by asking someone to assist you or by taping the rail to the transom, etc.

Be careful not to allow the rail to slip into the water before the nuts are tightened.

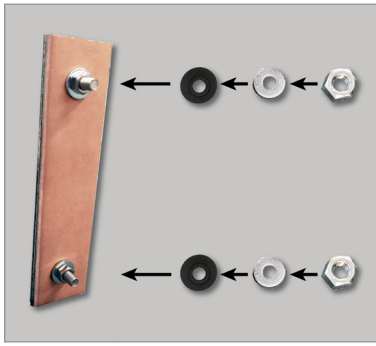

[Figure 10] A reinforcement board with washers and nuts installed.

Reinforcement board and tightening

- Apply sealant around the bolts on the inside.
- Place the reinforcement board over the bolts.
- Insert the washers and nuts.
- Tighten the nuts evenly by alternately tightening each one (Figure 10)

4.3 Mounting and dismantling the turbine

(Figure 11)

1. Slide the turbine (2) onto the axle (1). Ensure that the turbine wedge is aligned with the groove in the axle. When the turbine has been installed correctly on the axle, there is a gap of approximately 3 mm between the turbine and the generator.
2. Install an acid-resistant spring washer (3) under the acid-resistant M6x35 Allen screw (4).
3. Insert the screw and the spring washer through the hole in the turbine and use a hex key to tighten the turbine into place to a torque of 4.0 Nm.

[Figure 11] Components required for installing the turbine:

1. Axle
2. Turbine
3. Acid-resistant spring washer
4. M6x35 acid-resistant Allen screw

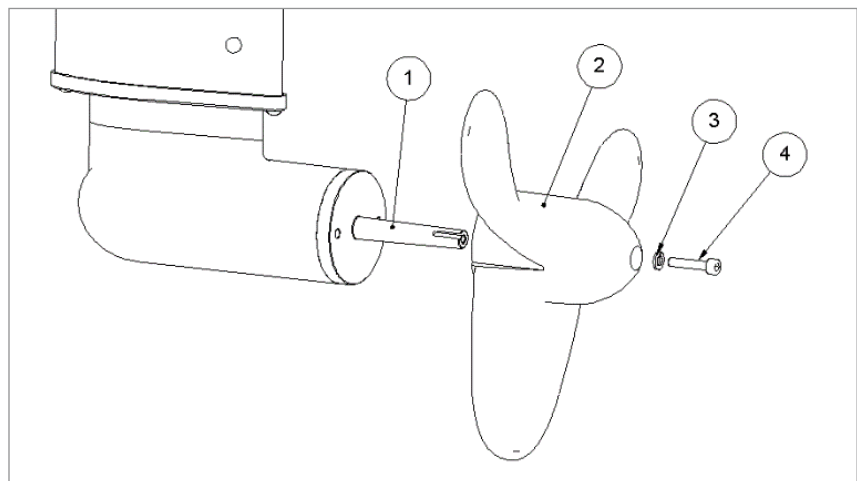

To dismantle the turbine, loosen the screw and pull the turbine off the axle. You can use thin screwdrivers or equivalent thin, flat tools on the opposite sides of the turbine to gently pry it off of the axle. Do not pull or twist the turbine blades.

4.4 Installing the charger

4.4.1 Installation location considerations:

- The charger must be installed in a dry indoor area in the boat as close to the hydrogenerator outboard unit as possible.
- Ensure that the charger is not exposed to water (e.g. dripping condensed water, etc.)
- To install the charger, use 4 pcs of 4 mm thick wood screws. The length of the screws depends on the installation location.
- Cooling: During charging, the charger unit may warm up considerably. Therefore, it is important to install the unit in a location where the ambient temperature does not rise significantly. Avoid installing it in the engine compartment or a similar space. The charger should always be installed in an upright position to ensure unobstructed and sufficient flow of air in the cooling element. That is why the minimum distance of the charger to the ceiling or other similar obstructions to the air flow should be 20 cm. The charger has a built-in temperature monitoring function. If the temperature becomes too high, the charger reduces its charging power and, if needed, stops the charging until the temperature drops to a safe level. Therefore, insufficient cooling weakens the charger's performance.
- The generator cables included in the sales package provide optimal charging power. If you are using longer cables, contact the manufacturer to make sure the cables are suitable for that length.
- Use a battery cable thick enough to connect the charger to the battery. Note that the charger measures and adjusts the power according to the battery connection, so between the charger and the battery there should be used charging wires with the largest possible cross-sectional area. ($\geq 10\text{mm}^2$ @12V ja $\geq 6\text{mm}^2$ @24V).

4.4.2 Installing the cable feedthrough

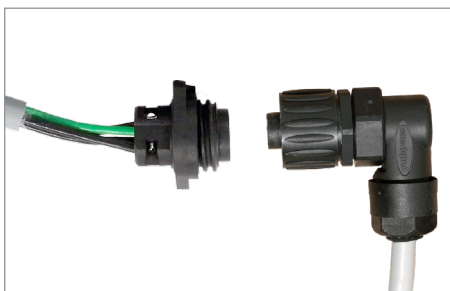

[Figure 12] Amphenol Ecomate Aquarius connector pair

The Remoran™ Wave 3 sales package includes a weather-resistant generator cable ($4 \times 2.5 \text{ mm}^2$) integrated in the outboard unit, as well as a cable to be installed in the space behind the feedthrough and intended for dry spaces, with a corresponding cross-sectional area and number of wires. Amphenol Aquarius Ecomate connectors have been factory-installed to the end of the wires. (Figure 12)

A 22-mm hole should be drilled in the desired location in the transom of the boat for the feedthrough of the cables (Figure 13). Ensure that the 2-metre generator cable reaches the feedthrough without becoming excessively taut, allowing the outboard unit to turn freely. Seal the feedthrough properly with the O-ring supplied with the connector and a sealant suitable for the purpose. After that, screw the connector into place (Figures 14 and 15).

The length of the dry area cable supplied in the sales package is 2 metres. The cable is connected to the charging unit in accordance with the numbering on the wires (see section 4.4.4 Connecting the cables to the charger).

4.4.3 Using extended generator cables

The device produces power according to the charging diagram when the turbine is in an undisturbed flow field and when the cables included in the sales package have been used for installation. If the cable lengths are extended, the charging power will decrease due to power dissipation. In case you need to lengthen the the cables, contact the manufacturer for more information.

The charging unit should be installed as close as possible to the hydrogenerator outboard unit. If the distance from the hydrogenerator to the batteries is long, we recommend using longer battery charging wires instead of extending the generator cables.

The outboard unit's integrated cable is a special product and designed to withstand marine conditions. In addition, the connector is factory-installed using a waterproof method. We do not recommend that you modify this cable. If you need a longer outboard unit cable, please contact the manufacturer. If the cable is too long, you should coil it up tightly to prevent it from becoming tangled with the ropes of the boat etc.

Generator cable. The cables inside the boat can be extended by using methods typically used in the boat's low-voltage electrical connections. We do not recommend detaching the feedthrough connector from the original cable; instead, the extension should be carried out at the end of the original cable.



[Figure 13] Drill a 22 mm hole to the boat transom for the feedthrough of cables

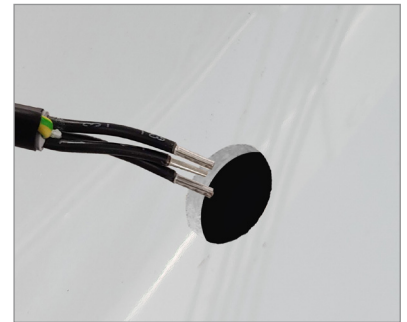

[Figure 14] Insert the generator cable into the hole so that the connector remains outside of the boat



[Figure 15] Fasten the connector with two wood screws

When making the extension, ensure that the new cable has the same number of wires and the same cross-sectional area than the original cable. Also note the numbering of the cable wires and connect the numbered wires of the cable to the corresponding numbered screw terminals of the charger.

4.4.4 Connecting the generator cables to the charger

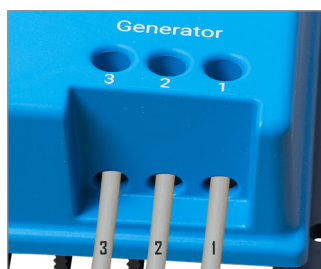

[Figure 16] The cables are numbered (1, 2, 3) and should be connected to the corresponding apertures.



[Figure 17] Carefully connect the charging wires to the appropriate apertures with the + and - wires in their appropriate locations.

Three wires of the generator cable are numbered and one wire is the protective earth (green-yellow). The numbered wires should be connected to the corresponding numbered screw terminals of the generator connection of the charger (Figure 16). The protective earth wire has been connected to the hydrogenerator's aluminium frame structure. If the operator so wishes, the protective earth wire can be connected to the boat's earth potential to prevent corrosion to the generator's mechanical parts. If the wire is not connected, it should be taped or, if needed, cut. Using the wire for any other purpose is strictly forbidden.

4.4.5 Connecting the charging wires to the charger

The **charging wires** (positive and negative) to be connected to the battery (Figure 17) should be selected so that the maximum charging current (25A) does not cause significant power loss (heat). The minimum cross-sectional area of the wire is 6 mm², but we recommend a 10 mm² wire to ensure optimal charging. The sales package does not include the wires but they can be ordered from our webstore. Also do not exceed the wire length of 3 metres.

The red charging wire (+ positive) should always be equipped with a 40 A circuit breaker (between the charger and the battery). Install the circuit breaker as close to the battery as possible (max. 30 cm). If you do not have a circuit breaker available, you can order one from our web store. There is no circuit breaker inside the charger.



[Figure 18] Ferrite filter

To ensure uninterrupted operation of the product, install a clamp-on ferrite filter on the positive charging wire (Figure 18). The ferrite filter is included in the sales package and should be installed as close to the charger as possible. When closing the plastic body of the ferrite around the wire, you should hear a click when the two pieces interlock. This ensures that the pieces are properly connected. If needed, they can be reopened by turning the clip on the side of the ferrite.

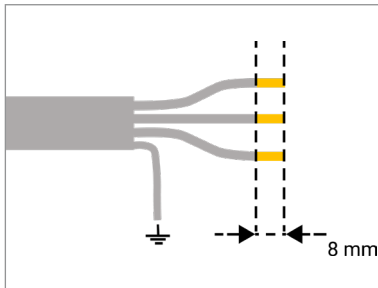

[Figure 19] Stripping length of the generator cable

When stripping the generator cable and the charging wire, use sufficient lengths in order to avoid short-circuits: The stripping length of the generator cable (Figure 19) and the stripping length of the charging wires (Figure 20). Roll the copper threads of the stripped cables into smooth bundles before inserting them into the charging unit. The threads must not bristle and touch adjacent screw terminals or wires!

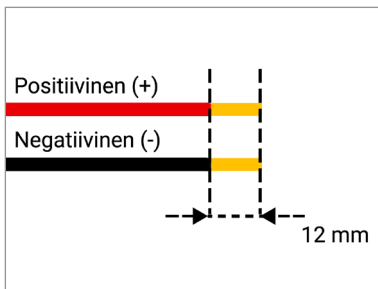

[Figure 20] Stripping length of the charging wires

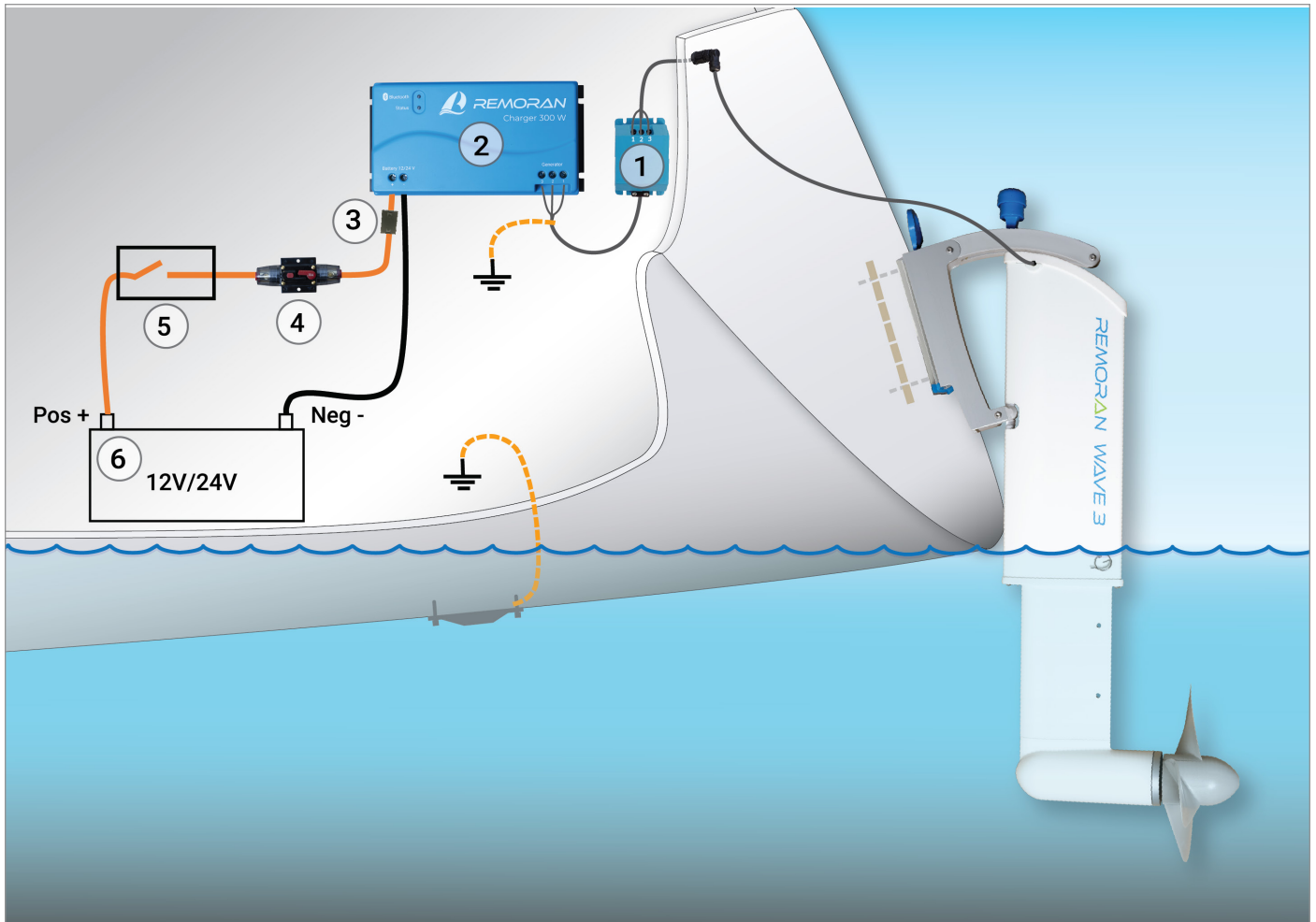

[Figure 21] Connection illustration

1. PR-01 protection relay (accessory)
2. Remoran Charger 300W
3. Ferrite filter
4. Fuse (40A)
5. Main switch
6. Battery



[Figure 22] The generator wires are connected to the chargers so that the wire numbers match the numbering of the screw terminals in the charger.

4.4.6 Circuit diagram

When connecting the hydrogenerator (Figure 21), first connect the wires of the generator (Figure 22). A rechargeable battery or battery pack may be connected only after that. The connections must always be performed on an unenergised product (the generator must not run). All connections must be performed carefully and in compliance with the electrical safety regulations.

5 OPERATING THE HYDROGENERATOR

5.1 Before operation



[Figure 23] Using a safety rope with the hydrogenerator



[Figure 24] Do not tie the safety rope to the locking handle

Ensure that the installation measures described in chapter 4 have been properly performed before you start operating the Remoran™ Wave 3 Hydrogenerator. We recommend that you use a safety rope in case the product falls into the water during mounting or dismounting. The connector of the outboard unit may be damaged if the product ends up hanging by its cable.

The proper way to install the safety rope is to pass it between the frame and the blade (Figure 23). The knot should be close to the locking handle to ensure that the loop is sufficiently tight and that the blade can move freely when the boat turns. Do not tie the safety rope to the locking handle (Figure 24).

Before setting sail, mount the outboard unit on the mounting rail and connect it to the feedthrough connector and ensure that the charger operates properly. To determine the status of the charger, observe the LED indicators or use the Remoran™ App mobile application.

5.1.1 Adjusting the height of the outboard unit

The height of the outboard unit is adjusted before operation so that the turbine remains submerged even when the boat tilts. (Figure 25)

1. Detach the locking pin cotter and pull out the pin.
2. Adjust the height by aligning the hole in the bottom blade with the hole in the upper blade
3. Attach the pin and the cotter

The length of the outboard unit can be shortened again after use to facilitate storing.

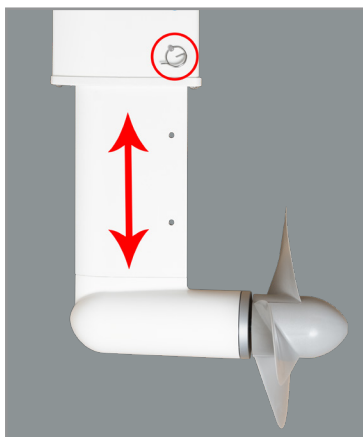

[Figure 25] Hydrogenerator's telescopic blade and locking cotter

The locking pin and the cotter must always be attached when the product is in use

The height of the outboard unit may not be adjusted when the boat is in motion

5.1.2 Mounting the outboard unit on the rail

Do not try to mount the generator on the boat when the boat is in motion! This may cause personal injuries or damage to the rail, outboard unit or boat. The outboard unit may even slip into the water.

1. Ensure that the turbine is properly attached to the outboard unit.
2. Ensure that a safety rope is attached to the outboard unit of the hydrogenerator.
3. Set angle adjustment to position 0 (straight).
4. Lift the handle so that it locks into the top position. (Figure 26)
5. Align the outboard unit with the rail fastened to the boat and slide the unit all the way down. (Figure 27)
6. Push the handle to the bottom position to lock the outboard unit to the rail. (Figure 28)
7. Adjust the angle of the outboard unit by pulling the angle adjustment knob and sliding the knob along the angle guide. (Figure 29) (For more detailed instructions, see chapter 5.1.3.)
8. Connect the cable connector to the feedthrough connector installed in the boat.



[Figure 26] Lift the locking handle to the top position before sliding the outboard unit onto the rail.



[Figure 27] Place the frame of the outboard unit to the top of the rail and slide it down along the rail.



[Figure 28] Lock the outboard unit onto the rail by pushing the handle down to the bottom position



[Figure 29] Adjust the outboard unit to a right angle in relation to the water surface

5.1.3 Adjusting the angle of the outboard unit

To ensure the best possible operation of the generator, adjust its position so that it is optimal (at a straight angle) in relation to the flow of water.

The angle adjustment range in Remoran™ Wave 3 is 0–40 degrees. This adjustment range is sufficient for most boats, and no additional adapter pieces are needed. If the adjustment range in your boat is not sufficient, be sure to take it into consideration in the installation stage. See chapter 4.

In most boats, the angle is always adjusted to the same position. Always adjust the angle to the proper position when mounting the outboard unit on the rail before setting sail.

Before dismounting the outboard unit from the rail, restore the angle to 0 degrees.



Do not adjust the angle of the outboard unit when the boat is in motion.

1. Pull upwards from the bottom part of the angle adjustment knob so that the knob raises up slightly. (Figure 30)
2. Move the angle adjustment knob along the angle guide in order to adjust the angle as desired. (Figure 31)
3. Adjust the angle of the product so that the outboard unit is perpendicular to the surface of the water.
4. Release the bottom part of the angle adjustment knob and ensure that it sets into the groove on the rail in order to lock the angle properly.

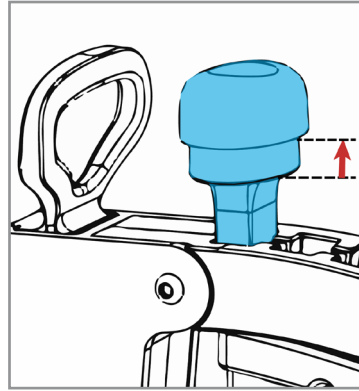

[Figure 30] Squeeze the angle adjustment knob to raise its bottom part

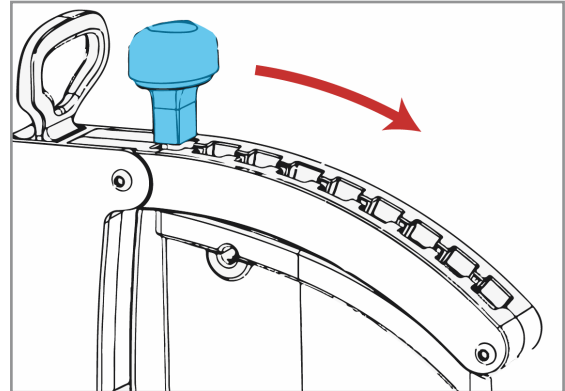

[Figure 31] With the angle adjustment knob squeezed, slide the knob along the angle guide to a desired position.

5.2 During sailing

The outboard unit must be mounted on the rail before setting sail. (See section 5.1) While sailing, the Remoran™ Wave 3 Hydrogenerator does not require any action.

The turbine of the outboard unit starts to rotate at the operating speed of 1–2 knots and charging begins automatically. The progress of charging can be monitored by observing the LED indicators on the charger (see section 6.6) or via the Remoran™ App mobile application.



Ensure that the boat's operating speed remains at or below the allowed 15 knots in order to prevent damage to the product.



Do not operate the boat in reverse for extended periods of time to avoid damage.

If you notice anything out of the ordinary during operation, refer to chapter 8 of this operating manual and the FAQ section on the manufacturer's website. You can also send your questions to us via e-mail at info@remoran.fi or by filling out the feedback form on our website.

5.3 Dismounting the outboard unit



Never dismount the outboard unit while the boat is in motion! This may cause personal injuries or damage to the rail, outboard unit or boat, and the outboard unit may slip into the water.

1. Ensure that the safety rope is properly fastened.
2. Adjust the angle of the hydrogenerator to zero position (straight).
3. Lift the locking handle to release the unit.
4. Slide the outboard unit upward and off of the rail while holding on to the locking handle and the end of the angle guide. (See Figure 26) The blade is heavy – beware of the swinging motion.

Disconnect the charging cable connector and the safety rope only when the outboard unit is safely on the deck of the boat if you are going to store the unit in the boat, for example.

6. OPERATING THE CHARGER

6.1 Before operating the charger

The charging unit **Remoran™ Charger 300W** is intended for use only with the Hydrogenerators manufactured or approved by **Remoran Oy**.



Do not connect the charger to or use it with other electric generators or equivalent products.

The charger is designed to charge batteries with a maximum charging voltage of no less than 14.4V / 28.8V in the constant voltage state (Nominal 12V or 24V batteries). See section 6.3 Charger Algorithms for more information and, if needed, verify the compatibility of your battery by contacting the battery manufacturer or Remoran Oy. Before operating the product, ensure that the connections have been made in accordance with sections 4.4.4 and 4.4.5 and that the product has been mounted in compliance with the mounting recommendations.

6.2 Operating the charger

The charger starts automatically when a rechargeable battery is connected to the charger. When the connection is made, the charger recognises the voltage (12V/24V) of the battery/battery pack to be charged. This action cannot be changed externally but the recognition always takes place only when the connection is being made.

The charger begins charging the battery when the generator connected to it starts running. The charger operates fully independently and controls the charging depending on the charging status and the rotation speed of the generator. The charger indicates its operating status by means of the LED indicators on the front panel (see section 6.6 Charger LED indicators).

6.3 Charger's charging algorithms

The charger can be used to charge both conventional lead acid batteries and lithium batteries. Due to the differences between battery technologies, the charging algorithms also differ slightly. The charging of a lead acid battery uses the floating stage to "finalise" the charging, whereas the lithium battery does not require this stage. The charger switches to the different stages of the charging algorithm automatically, depending on the charging status of the battery at that time.



The operator can select the algorithm to be used in the charger software version 2.0 and later in the Remoran™ App mobile application. Earlier program versions use a two-stage Lithium battery algorithm.

Note that the maximum charging power is reached at the operating speed of approximately 10 knots. In the CC stage, the power may fluctuate from close to zero all the way to the maximum (300W), depending on the rotation speed of the generator, or the operating speed of the boat. The charging current is the result of the power generated by the charger divided by the voltage of the battery pack at that time.

Two-stage algorithm for a lithium battery

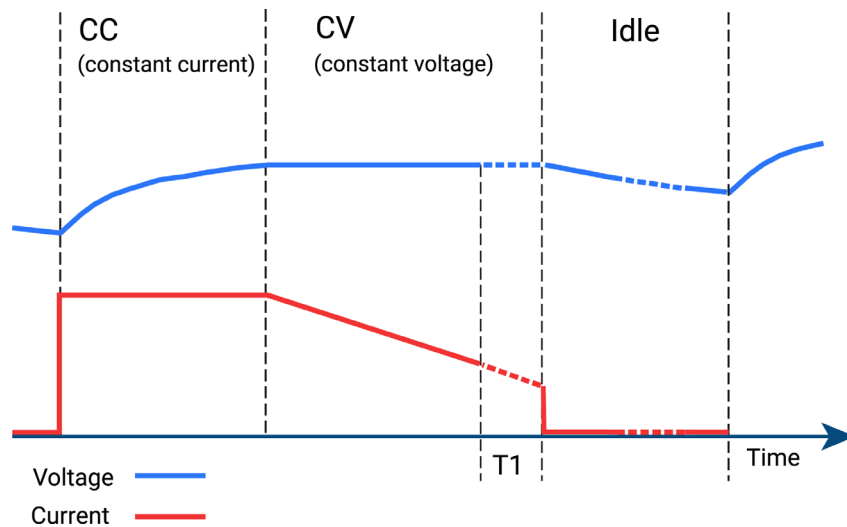

Charging stage	Voltage (V)		Maximum charging current (A)		Duration
	with a 12V battery pack	with a 24V battery pack	with a 12V battery pack	with a 24V battery pack	
CC	-	-	25	12.5	
CV	14.4	28.8	-	-	T1=5min@<1A
Idle	13.6	27.2	-	-	

Contact the battery manufacturer to ensure that the cell-specific maximum and minimum voltage values generated through the algorithm are allowed for the battery in question:

For example, with four internal cells:
 cell maximum voltage = $14.4 / 4 = 3.6V$
 cell maximum voltage = $13.6 / 4 = 3.4V$

If the lithium battery is equipped with a separate BMS unit, follow the instructions provided by the unit manufacturer and, if needed, contact Remoran Oy to ensure compatibility/connection.

Three-stage algorithm for a lead acid battery

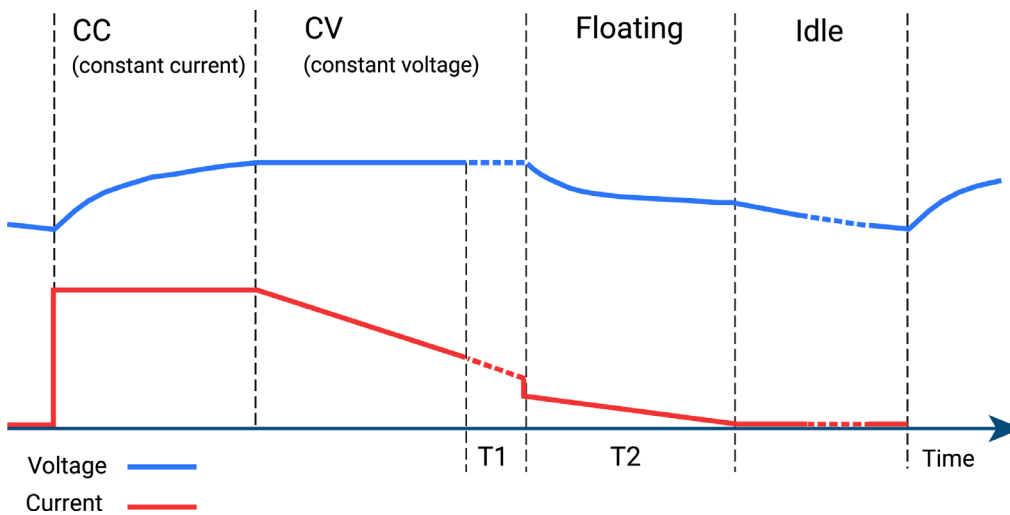

Charging stage	Voltage (V)		Maximum charging current (A)		Duration
	with a 12V battery pack	with a 24V battery pack	with a 12V battery pack	with a 24V battery pack	
CC	-	-	25	12.5	
CV	14.4	28.8	-	-	T1=3h@<2A
Floating	13.5	27	-	-	T2=4h@<2A
Idle	12.8	25.6	-	-	

Note: The charger switches from the floating state back to the CC state if the charging current exceeds 5A for more than one minute.

6.4 Short-circuit of the charger

The charger automatically measures the voltage and current of the battery being charged. If the voltage decreases too much, the charger interprets the situation to be abnormal, which may be due to a battery breakdown (one or more cells are damaged), a short-circuit, etc. If the charger is connected to the battery that is also used as a starter battery, the voltage drop may also be due to a starting action. The charger recovers from the fault state to normal operation after 30 seconds. If the fault situation continues (a low voltage under 8V in a 12V system or under 16V in a 24V system), the abnormal situation is recognised again. Note: if the voltage in the charging connector (battery) drops to below 6V, the charger switches off automatically (even if the turbine produced voltage).

6.5 Backup battery of the charger clock

The charger is equipped with an internal clock circuit. The operations of the clock circuit are backed up with a BR1225 (3V) lithium battery. The computed service life of the battery is approximately ten years. The operator is notified through the application when the battery is due for replacement.

The battery is replaced by opening the charger cover (six screws underneath the charger). The battery sits in a metal holder and can be detached from the holder by pushing the battery towards the edge of the printed circuit board (Figure 32). To install a battery, carry out the steps in the opposite order. Note the orientation (the plus and minus terminals) of the battery. After replacing the battery, the time and date must be set in the mobile application. You can also send the charger to the factory for battery replacement and for time and date reset. Depending on the capacity (mAh) of the installed battery, the new service life may vary considerably from the original service life.

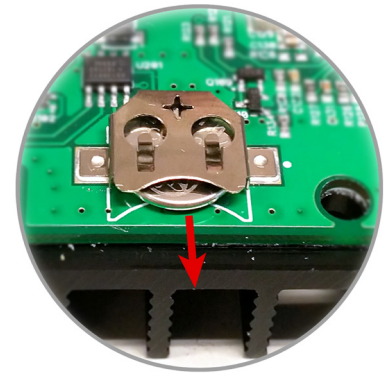

[Figure 32] Backup battery

6.6 Charger LED indicators

There are two LED indicators on the front panel of the charger: "Status" and "Bluetooth" (Figure 33).

The colours of the Status LED indicator are green, red and orange. The LED indicator may also blink. The Bluetooth indicator is blue.

The table below shows the meaning of the different colours of and signals given by the LED indicators.

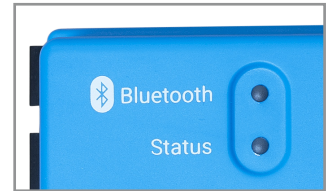

[Figure 33] Charger LED indicators: Bluetooth® and Status indicators

LED INDICATORS (A 3-SECOND CYCLE)	EXPLANATION	MEANING
STATUS LED; NORMAL OPERATION		
	No light	The charger is not on Connect the charger to the battery
	Orange flashes once	The battery could be charged but the generator's running action is not sufficient
	Steady orange	Charging in progress (CV and CC status)
	Steady green	The battery is almost full (floating status)
	Green flashes once	The battery is full (idle status)
STATUS LED; FAULTS		
	Red blinks slowly	Defective battery
	Red blinks at a medium speed	Excessive temperature (over 80°C)
	Red blinks fast	Excessive temperature (over 90°C)
	Steady red	Short-circuit
	1 red flash and 1 orange flash	Generator wire 1 is disconnected
	1 red flash and 2 orange flashes	Generator wire 2 is disconnected
	1 red flash and 3 orange flashes	Generator wire 3 is disconnected
BLUETOOTH LED STATUSES		
	Steady blue	A wireless Bluetooth connection has been established
	No blue light	The device is waiting for a Bluetooth connection

7. TECHNICAL SPECIFICATIONS

7.1 Hydrogenerator outboard unit

- Weight 7.5 kg
- Gradual height adjustment in the range of 68 cm – 98 cm
- Brushless 3-phase generator
- Permanent magnet rotor
- Main voltage 22VAC @2000RPM
- Angle adjustment 0–40 degrees at 5-degree intervals
- Automatic turning of the blade with the flow of the water
- Three-bladed turbine, diameter 24 cm
- The turbine has been optimised for the operating speed of 3–10 knots
- Maximum operating speed 15 knots

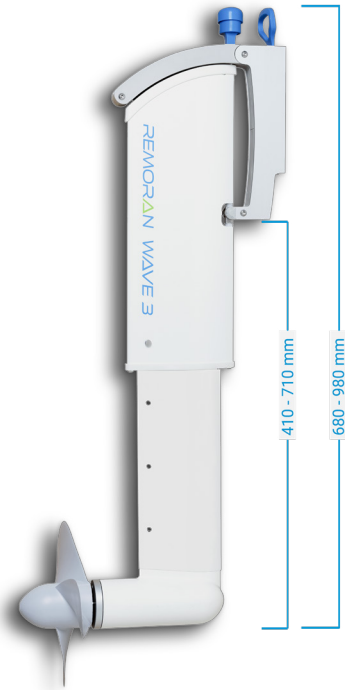

7.2 Charger

Electrical properties:

- Maximum allowed input voltage 35VAC (three-phase)
- Output voltage 12V/24V
- Output current max. 25A
- Output power max. 300W
- Collection of charging data (power, temperature, RPM, etc.)
- Power consumption on standby mode 20mA
- Bluetooth® communication
- Protection rating IP32
- Compatible batteries: Pb, AGM, Lithium
- Operating temperature range: -10°C – +55°C

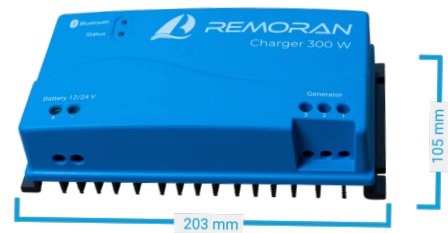

Mechanical properties:

- dimensions: 53 mm x 203 mm x 105 mm
- weight: 620 g

7.3 Performance

The power values in Figures 34, 35 and 36 are the maximum values for the operating speed in question. The power yield depends on the location of the installed outboard unit and the cleanliness of the turbine. There are two variants for Remoran Wave 3 -hydrogenerator: GS and GD. Variants have been optimized for boats of different speeds.

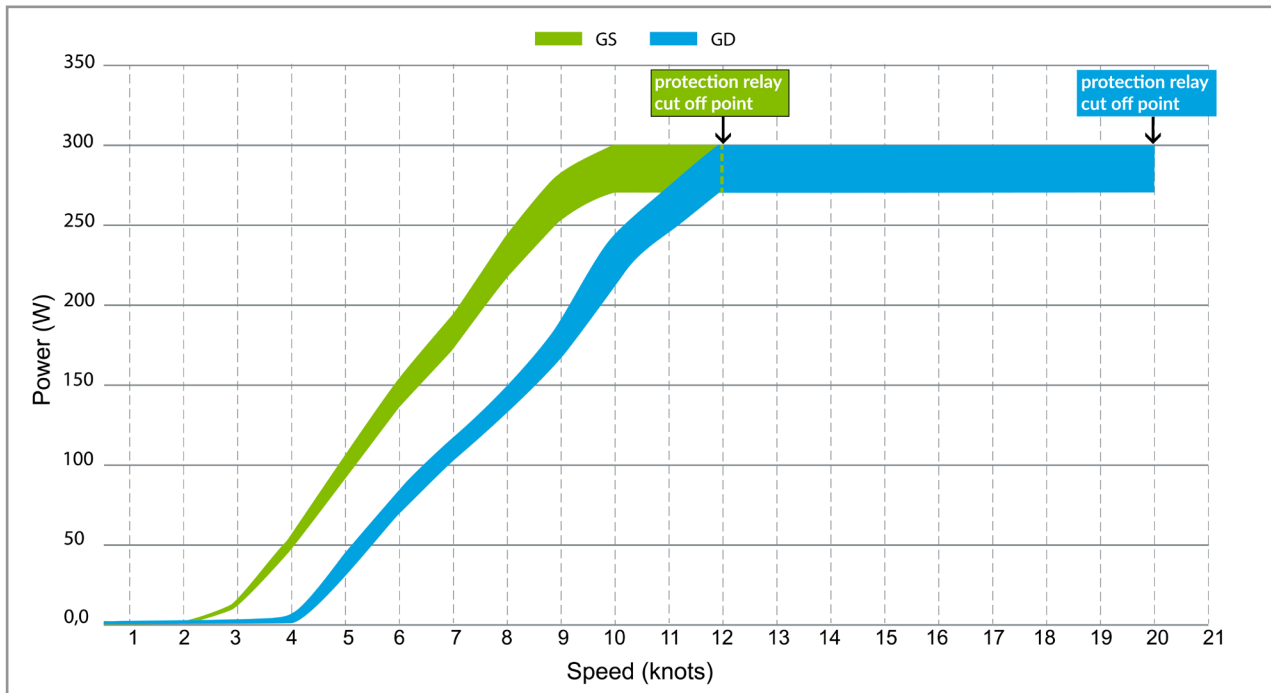

[Figure 34] Power at different operating speeds

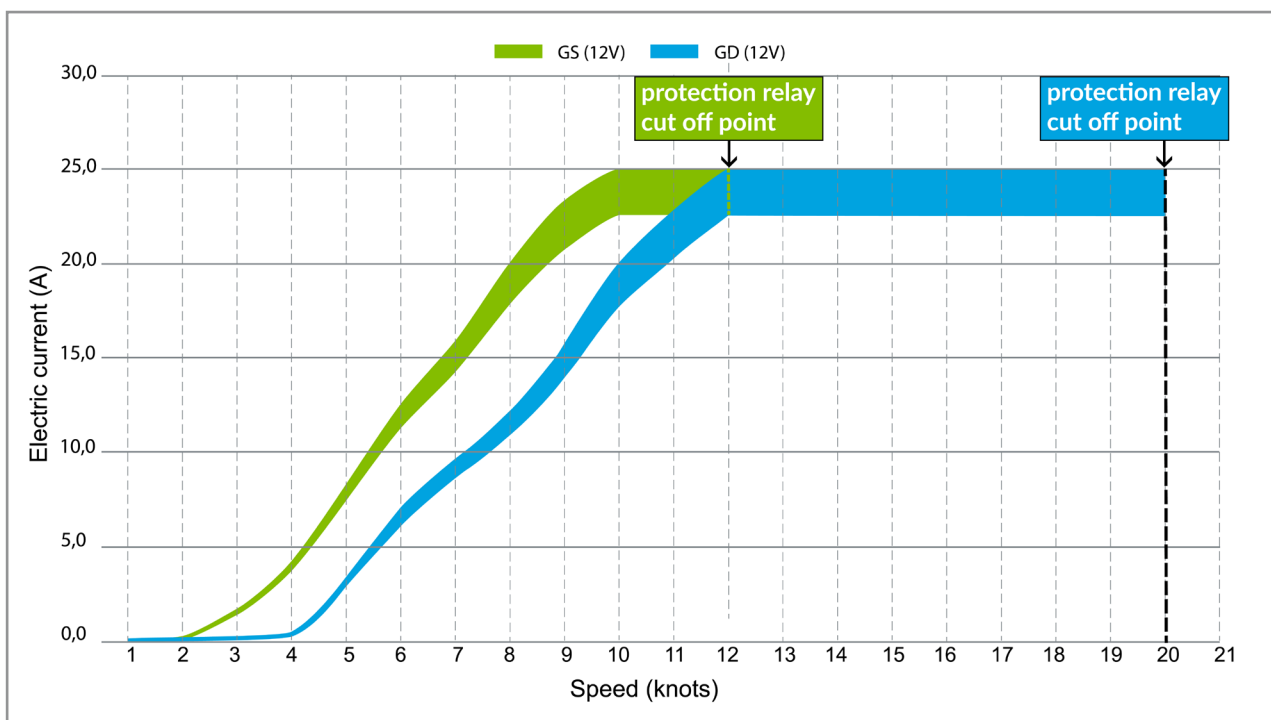

[Figure 35] Charging current at different operating speeds in 12V system

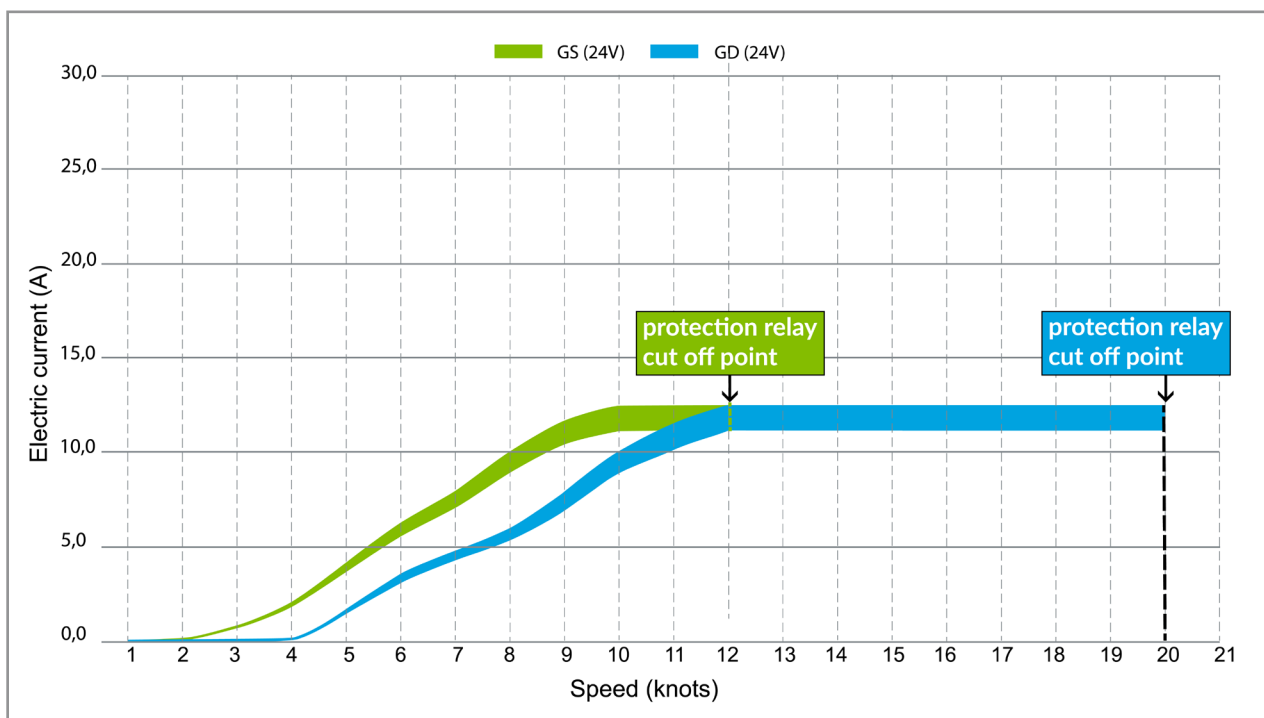

[Figure 36] Charging current at different operating speeds in 24V system

7.4 Protection relay

Remoran PR-01 is a separate accessory that protects the Remoran Charger 300W from generator (outboard unit) overvoltage. A potential overvoltage condition occurs when the generator rotation exceeds the design speed. There is no risk of overvoltage when using Remoran Wave 3 in the sailing speed range for the device. However, if you often sail close to the maximum speeds, or it is possible that you will exceed it even momentarily, we recommend that you use Remoran PR-01 to protect the charger from damage. The PR-01 is a fully automatic protection unit that does not contain a battery, accumulator, etc.

The PR-01 receives the electrical energy needed for operation from the three-phase generator voltage and is therefore ready for operation as soon as the generator begins to generate voltage (the boat is moving). The PR-01 disconnects the connection between the outboard unit and the charger if the voltage is roughly 40 VAC (line-to-line). When the speed of the boat decreases and the generator voltage drops, the PR-01 restores the electrical connection between the generator and the charger and the charging function resumes. The difference between the cut-off and return voltage is about 5 VAC (hysteresis). This ensures that disconnection and recovery events do not occur incorrectly in succession (oscillation). Check the cut-off points from the figures 34, 35 and 36.

8. TROUBLESHOOTING

8.1 Outboard unit issues and malfunctions

Issue	Possible cause and solution
The boat is in motion but the turbine does not rotate	The speed may be too low (less than 2 knots) OR The turbine may be obstructed by fishing line or seaweed entangled in it, for example. Stop the boat, pull the unit onboard and remove the obstruction.
The outboard unit vibrates	A mild vibration is normal, but a strong vibration may be due to an object, such as fishing line, having become entangled in the turbine, or a damaged turbine. Stop the boat, lift the unit from the water and check the turbine. If needed, remove the obstruction.
The outboard unit makes a humming sound when the boat is in motion.	A faint sound is normal. The sound may be more discernible when sailing downwind. When sailing sidewind, the regular sounds of sailing usually cover the humming of the generator. You can try and dampen the sound by using acoustic materials on the inside of the boat's transom, especially if there is a large space acting as a soundbox behind the mounting spot. You can install a piece of a 2–3 mm thick rubber mat under the mounting rail.
Oil leaks from the outboard unit	The generator is filled with oil. If the oil leaks out, contact the manufacturer.

8.2 Charging issues

Fault situations are indicated by the Status LED on the front panel of the charger (see section 6.6 Charger's LED indicators) and in the Remoran™ App mobile application.

Issue	Possible cause and solution
Charger error code – Excessive heat	<p>The charger monitors the operating temperature, and if the limit value of +80°C is exceeded, the charging power is reduced to 80 per cent of the maximum (300W => 240W). If the temperature continues to rise and reaches +90°C, charging is discontinued. In both cases, regular charging continues once the charger has cooled down to the temperature of approximately +40°C.</p> <p>If the charger's temperature is continuously excessive, ensure that the ventilation of the charger cooling fins is not obstructed. Feel free to contact the manufacturer if you have questions about the sufficiency of ventilation.</p>
Charger error code – Phase conductor break	<p>If there is a break in one of the wires, the charger indicates the number of the wire by means of flashing or blinking LED indicators (see section 6.6) and in the Remoran™ App mobile application. The charger cannot indicate a simultaneous break in more than one wire.</p> <p>In the case of a phase conductor break, the operator should try to locate the break by checking the tightness of the generator connector screws in the charger and the connections of the feedthrough connector and any extensions.</p>
The generator runs but the charger's LED indicators are not lit and the Remoran™ App mobile application cannot establish a connection	<p>The battery is not connected to the charger.</p> <p>The charger will not start without a battery.</p>
The boat is in motion but the battery is not charging (an orange LED flashes once)	<p>The turbine does not rotate. The boat's operating speed may be too low or something is obstructing the turbine.</p>
The charger does not charge (a green LED indicator flashes once)	<p>The charger detects that the battery is full (battery voltage over 13.6V (in the 12V system) or 27.2V (in the 24V system)). Any parallel charging systems, such as solar panels, may increase the battery voltage.</p>

<p>The charger's output power is not as specified</p>	<p>There may be too much turbulence in the flow field. Check that the outboard unit is not installed in the line of the rudder, for example.</p> <p>The turbine does not necessarily rotate properly. Ensure that the turbine is not obstructed by, for example, seaweed entangled in it.</p>
---	--

8.3 Bluetooth connection issues

Issue	Possible cause and solution
<p>Remoran™ App cannot connect to the charger. The blue LED indicator is on.</p>	<p>Another device has already established a Bluetooth connection with the charger. Only one connection is possible at a time.</p> <p>Disconnect the connected device from the charger, after which a new connection can be established.</p> <p>The disconnection can also be achieved by restarting the charger (by momentarily disconnecting it from the battery).</p>
<p>Remoran™ App cannot connect to the charger. The blue LED indicator is off.</p>	<p>The charger may be too far away, or a malfunction is preventing the connection.</p> <p>Open the connection closer to the charger.</p> <p>Ensure that there are no sources of disturbance or metal surfaces near the charger (e.g. enclosing the charger in a metal cabinet will block a radio connection).</p>

9. MAINTENANCE

The product is designed for long-term use and requires only minimal maintenance. However, the operator should carry out the following inspections and maintenance measures before the operating season begins and more frequently, if needed:

- Inspection of the tightness of all connecting screws of the charger unit and the connections of the circuit breaker.
- Inspection of the cleanliness of the battery terminals and the tightness of the contacts of the charging wires.
- Inspection of the tightness of the feedthrough connector and the cleanliness of the contact pins.
- Inspection of the firmness of the mounting rail and the tightness of the bolts.
- Detach the turbine from the generator and:
 - o Clean the axle carefully.
 - o Check for oil leaks (the generator is filled with oil).
 - o Reinstall the turbine and tighten as instructed.
- Wax the surface of the outboard unit to keep it clean longer

During the season, the product is nearly maintenance-free. Dry the product after use and inspect the parts. If needed, replace worn parts, such as the turbine, if there are signs of damage.

After the sailing season rinse the outboard unit with fresh water to get rid of the salt and dirt and dry it before putting it to the storage.

Store in a dry place.

In any maintenance-related matters, feel free to contact the distributor or contact us directly at info@remoran.fi.

10. PRODUCT DISPOSAL

10.1 Disposal of the hydrogenerator

The hydrogenerator is manufactured from recyclable materials, mainly aluminium, stainless steel and copper. The entire product, with the exception of the turbine, can be taken to metal recycling. The turbine should be disposed of as plastic waste.



The generator unit contains a small quantity of oil, which can be drained by opening the generator's end cap.

If you want, you may also send the outboard unit to the manufacturer for disposal.

10.2 Disposal of the charger

The charger has been manufactured in compliance with the RoHS directive, and the charger can be recycled as regular WEEE waste. If you want, you may also send the charger to the manufacturer for disposal.

11. SUPPLIES AND SPARE PARTS

Code	Name	Image
RE1001	Remoran™ Wave 3 outboard unit	
RE1007	Turbine kit	
RE1006	Standard rail kit	
RE1008	Locking pin set	
RE1005	Feedthrough connector kit female	
RE1009	Feedthrough connector kit male	
RE1002	Remoran™ charger 300W	
EL1008	Circuit breaker, automatic 40A	
EL1007	Generator cable 4x2.5 mm ²	
EL1006	Battery wire 10 mm ² Red	
EL1005	Battery wire 10 mm ² Black	
SP1004	Remoran PR-01 Protection relay	

12. WARRANTY

Warranty coverage and warranty period

Our products are designed for specific operating conditions. Our customers are responsible for ensuring that our products are operated appropriately. We grant the product a **two-year warranty**, which covers any manufacturing defects. The product's warranty period starts from the date of purchase. The warranty is limited to the replacement of a defective part/parts or, if needed, the entire product.

Remoran is responsible for defects occurred during shipment and the delivered products in accordance with the applicable law. If the products you receive are defective, are not the products you ordered, or if your shipment is incomplete or the products were damaged during transport, please contact Remoran's customer service immediately. For more detailed instructions concerning returns, see [https://remoran.eu/legal/Withdrawal_form_Remoran.pdf].

If such shipment errors occur or if the products you receive are defective in accordance with the definition provided in the applicable law, Remoran must correct these errors and defects without delay. If the claim results in the return of the products to Remoran, Remoran will cover the shipping costs of such returns.

Please contact our customer service before returning a product. Only returns approved in advance will be covered by the warranty. To submit a reclamation, please use the contact form available in Remoran's web store.

All returned systems or parts must be accompanied by a warranty claim form (see below) with the following information: customer's name and address, date of purchase (subject to proof), type of boat, defective parts, description of a structural or design defect and description of the conditions in which the system was operated.

The returned parts/products will not be reimbursed to the customer but they will be replaced with new parts.

The warranty does not cover the following situations:

- The product is damaged due to gross or intentional negligence.
- The product has been altered or modified without authorisation.
- The product has not been installed in accordance with the installation instructions supplied with the product.
- The product has been installed or maintained in an improper manner.
- The product has been used in deviation of this operating manual.

The warranty does not cover errors that are caused by regular wear and tear or normal ageing of materials and structures, scratches, cracks and defects caused by impact.

Remoran shall under no circumstance be liable for specific, incidental or indirect damage.

If you experience issues with your Remoran™ hydrogenerator, please contact our customer service.

13. FAQ

We have collected the answers to our customers' frequently asked questions in the FAQ section of our website at www.remoran.eu.



The Bluetooth® word mark and logos are registered trademarks owned by Bluetooth SIG, Inc. and any use of such marks by Remoran Oy is under license. Other trademarks and trade names are those of their respective owners.

14. DECLARATION OF CONFORMITY

14.1 Supplier's Declaration of Conformity 47 CFR § 2.1077 Compliance Information

Product Name: Remoran Charger 300W

Product Model: MA-1

Manufacturer:

Remoran Oy
Harventajankuja 3, 24130 Salo, Finland
info@remoran.eu
www.remoran.eu

Modular Components Used:

NAME: Wi-Fi & Bluetooth Module
MODEL:ESP32-WROOM-32
FCC ID: 2AC7Z-ESPWROOM32

This device complies with part 15 of the FCC Rules. Operation is subject to the following two conditions: (1) This device may not cause harmful interference, and (2) this device must accept any interference received, including interference that may cause undesired operation.

FCC Compliance Statement

Contains FCC ID: 2AC7Z-ESPWROOM32

CAUTION: The manufacturer is not responsible for any changes or modifications not expressly approved by the party responsible for compliance. Such modifications could void the user's authority to operate the equipment.

NOTE: This equipment has been tested and found to comply with the limits for a Class B digital device, pursuant to part 15 of the FCC Rules. These limits

are designed to provide reasonable protection against harmful interference in a residential installation. This equipment generates, uses, and can radiate radio frequency energy, and if not installed and used in accordance with the instructions, may cause harmful interference to radio communications. However, there is no guarantee that interference will not occur in a particular installation. If this equipment does cause harmful interference to radio or television reception, which can be determined by turning the equipment off and on, the user is encouraged to try to correct the interference by one or more of the following measures:

- Reorient or relocate the receiving antenna.
- Increase the separation between the equipment and receiver.
- Connect the equipment into an outlet on a circuit different from that to which the receiver is connected.
- Consult the dealer or an experienced radio/TV technician for help.

ISED Compliance Statement

Contains IC: 21098-ESPWROOM32

This Class B digital apparatus complies with Canadian ICES-003.

Cet appareil numérique de la classe [B] est conforme à la norme NMB-003 du Canada.

CAN ICES-003 (B)/NMB-003(B)

ATTACHMENT 1 PRODUCT RETURN FORM

Cancellation form

Please fill in and return this form only if you wish to cancel the agreement.

Recipient Remoran Oy
Harventajankuja 3, 24130 Salo, Finland
Email: sales@remoran.fi

I hereby notify that I am willing to exercise my right of withdrawal and withdraw from the contract concluded by me on the purchase of the following product(s):

Date of order

Order number (if known)

Name

Address

Date

Signature*

(*only if you are using a paper copy of the form)

ATTACHMENT 2 COOLING PLATE INSTALLATION GUIDE

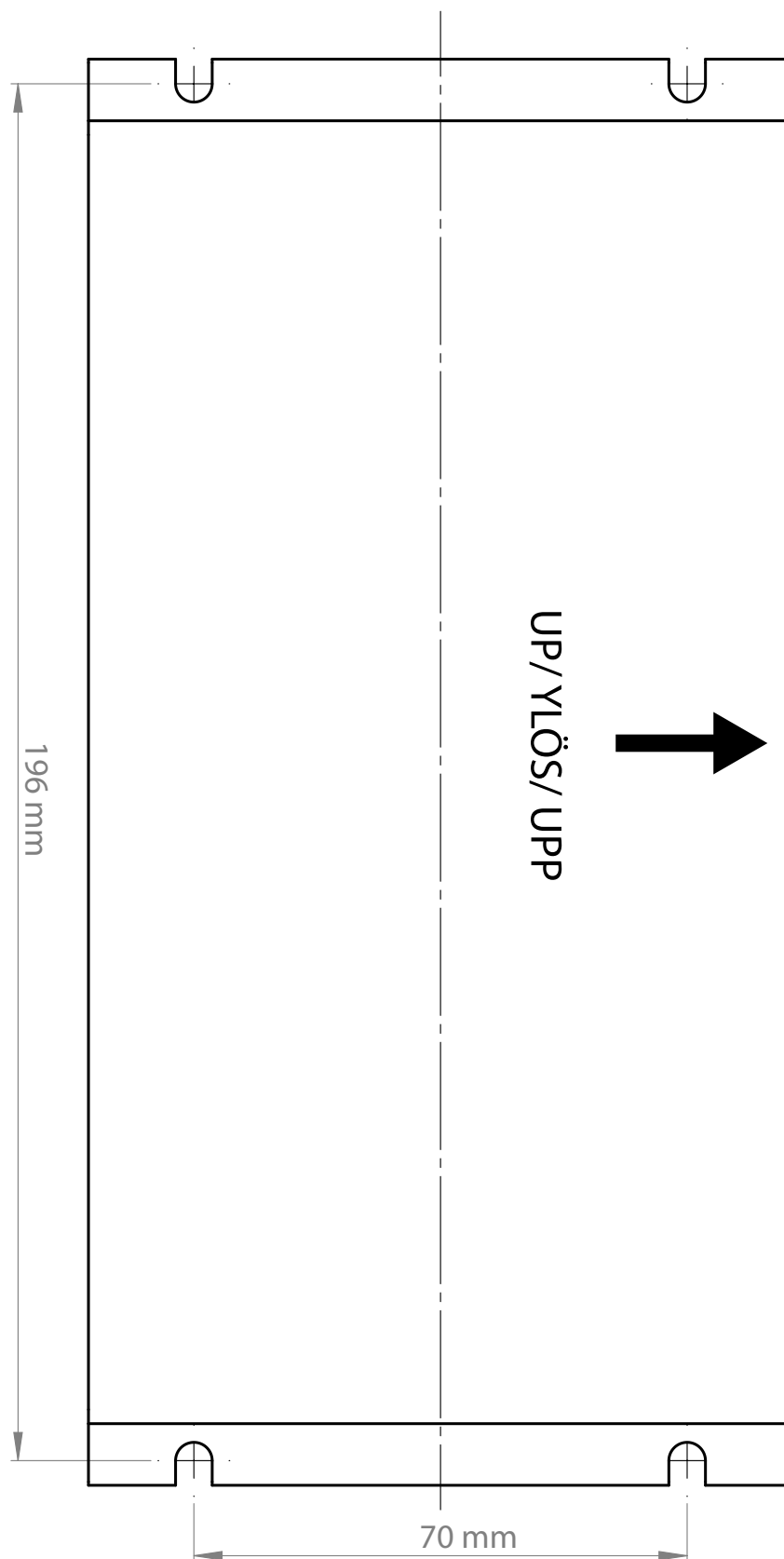

Scale A4 1:1



Remoran Oy

Harventajankuja 3,
FI-24130 Salo, Finland
info@remoran.fi
www.remoran.eu