

Product name	Description	Version
LS23060	GPS mouse/ATMEL ANTARIS4, 2m,USB,9600BPS	1.0
LS23062	GPS mouse/ATMEL ANTARIS4, 2m,PS2,9600BPS	
LS23063	GPS mouse/ATMEL ANTARIS4, 3m,RJ11,9600BPS	
LS23065	GPS mouse/ATMEL ANTARIS4, 5m,PS2 with lock,9600BPS	
LS23066	GPS mouse/ATMEL ANTARIS4, 3m,RJ11,9600BPS	

Datasheet of GPS mouse, LS2306x series

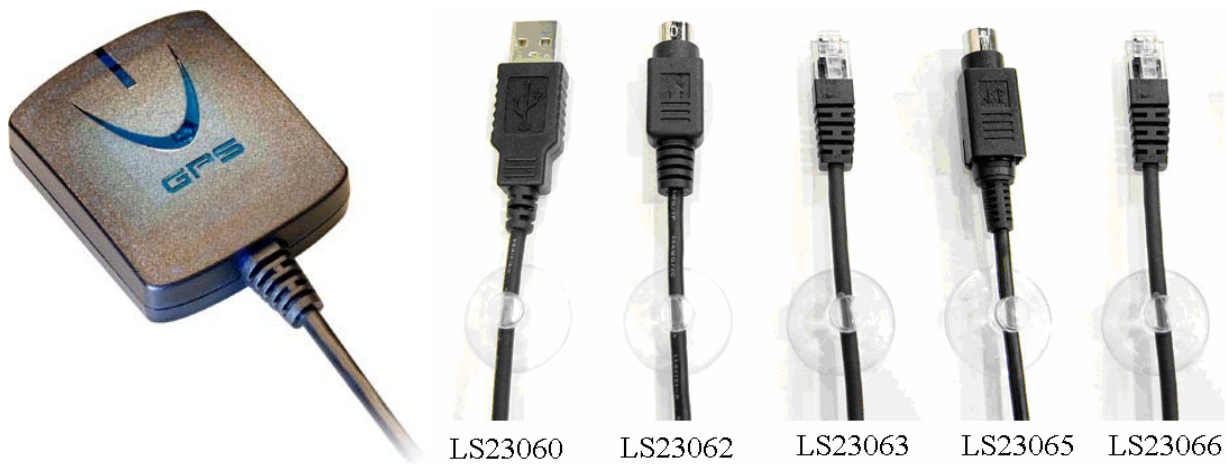

1 Introduction

LS2306x series products are complete GPS receivers (also known as GPS mouse) based on the proven technology found in LOCOSYS 16 channel GPS SMD type receivers AC-1513 that use ATMEL ANTARIS™ 4 SuperSense solution. The GPS mouse will track up to 16 satellites at a time while providing one-second navigation update (up to 4 Hz) and low power consumption. It can provide you with excellent navigation accuracy along with maximum sensitivity even in urban canyon and dense foliage environment. Its far-reaching capability meets the sensitivity requirements of car navigation as well as other location-based applications.

2 Features

- ATMEL ANTARIS™ 4 SuperSense solution
- Support 16-channel GPS
- Excellent navigation accuracy along with maximum sensitivity
- Capable of SBAS (WAAS, EGNOS)
- Build-in micro battery to reserve system data for rapid satellite acquisition
- LED indicator for GPS fix or not fix
- Magnet for mounting on the car
- Skid resistant pad on the bottom
- Waterproof

3 Application

- Personal positioning and navigation

- Automotive navigation
- Marine navigation

4 GPS specification

GPS Chip	ATMEL ANTARIS™ 4, ATR0635	
Frequency	L1 1575.42MHz, C/A code	
Channels	16	
Update rate	1Hz (default), up to 4 Hz	
Acquisition Time	Hot start (Open Sky)	4s (typical)
	Cold Start (Open Sky)	42s (typical)
Position Accuracy	Autonomous	2.5m CEP
	SBAS	2.0m CEP (depends on accuracy of correction data)
Datum	WGS-84 (default)	
Max. Altitude	< 18,000 m	
Max. Velocity	< 515 m/s	
Protocol Support	NMEA 0183 ver 2.3	9600 bps, 8 data bits, no parity, 1 stop bits (default) 1Hz: GGA, GLL, GSA, GSV, RMC, VTG, ZDA
	UBX Binary	38400 bps, 8 data bits, no parity, 1 stop bits

5 Software interface

5.1 NMEA output message

Table 5.1-1 NMEA output message

NMEA record	Description
GGA	Global positioning system fix data
GLL	Geographic position - latitude/longitude
GSA	GNSS DOP and active satellites
GSV	GNSS satellites in view
RMC	Recommended minimum specific GNSS data
VTG	Course over ground and ground speed
ZDA	Time and date

- **GGA--- GPS fix data**

Table 5.1-2 contains the values for the following example:

\$GPGGA,081727.00,2500.00033,N,12159.99915,E,1,11,0.73,56.0,M,16.1,M,,*62

Table 5.1-2 GGA Data Format

Name	Example	Units	Description
Message ID	\$GPGGA		GGA protocol header

UTC time	081727.00		hhmmss.sss
Latitude	2500.00033		ddmm.mmmm
N/S indicator	N		N=north or S=south
Longitude	12159.99915		dddmm.mmmm
E/W Indicator	E		E=east or W=west
Position Fix Indicator	1		See Table 5.1-3
Satellites Used	11		Range 0 to 12
HDOP	0.73		Horizontal Dilution of Precision
MSL Altitude	56.0	mters	
Units	M	mters	
Geoid Separation	16.1	mters	
Units	M	mters	
Age of Diff. Corr.		second	Null fields when DGPS is not used
Diff. Ref. Station ID			
Checksum	*62		
<CR> <LF>			End of message termination

Table 5.1-3 Position Fix Indicators

Value	Description
0	No fix or invalid
1	GPS SPS Mode, fix valid
2	Differential GPS, SPS Mode, fix valid
6	Estimated (DR) fix

● GLL--- Geographic Position – Latitude/Longitude

Table 5.1-4 contains the values for the following example:

\$GPGLL,2500.00033,N,12159.99915,E,081727.00,A,A*66

Table 5.1-4 GLL Data Format

Name	Example	Units	Description
Message ID	\$GPGLL		GLL protocol header
Latitude	2500.00033		ddmm.mmmm
N/S indicator	N		N=north or S=south
Longitude	12159.99915		dddmm.mmmm
E/W indicator	E		E=east or W=west
UTC time	081727.00		hhmmss.sss
Status	A		A=data valid or V=data not valid
Mode	A		N=no fix, A=autonomous, D=DGPS, E=DR

Checksum	*66		
<CR> <LF>			End of message termination

● GSA---GNSS DOP and Active Satellites

Table 5.1-5 contains the values for the following example:

\$GPGSA,A,3,02,04,07,10,13,24,05,29,30,27,26,,1.42,0.73,1.22*08

Table 5.1-5 GSA Data Format

Name	Example	Units	Description
Message ID	\$GPGSA		GSA protocol header
Mode 1	A		See Table 5.1-6
Mode 2	3		See Table 5.1-7
ID of satellite used	02		Sv on Channel 1
ID of satellite used	04		Sv on Channel 2
....		
ID of satellite used			Sv on Channel 12
PDOP	1.42		Position Dilution of Precision
HDOP	0.73		Horizontal Dilution of Precision
VDOP	1.22		Vertical Dilution of Precision
Checksum	*08		
<CR> <LF>			End of message termination

Table 5.1-6 Mode 1

Value	Description
M	Manual- forced to operate in 2D or 3D mode
A	Automatic-allowed to automatically switch 2D/3D

Table 5.1-7 Mode 2

Value	Description
1	Fix not available
2	2D
3	3D

● GSV---GNSS Satellites in View

Table 5.1-8 contains the values for the following example:

\$GPGSV,3,1,12,02,53,357,40,04,47,057,40,07,42,156,40,10,49,269,40*7A

\$GPGSV,3,2,12,13,25,046,40,24,15,089,40,05,15,272,40,29,20,194,40*7C

\$GPGSV,3,3,12,30,07,298,40,27,07,100,40,26,07,198,40,08,04,129,*7F

Table 5.1-8 GSV Data Format

Name	Example	Units	Description
------	---------	-------	-------------

Message ID	\$GPGSV		GSV protocol header
Total number of messages ¹	3		Range 1 to 3
Message number ¹	1		Range 1 to 3
Satellites in view	12		
Satellite ID	02		Channel 1 (Range 01 to 32)
Elevation	53	degrees	Channel 1 (Range 00 to 90)
Azimuth	357	degrees	Channel 1 (Range 000 to 359)
SNR (C/No)	40	dB-Hz	Channel 1 (Range 00 to 99, null when not tracking)
Satellite ID	10		Channel 4 (Range 01 to 32)
Elevation	49	degrees	Channel 4 (Range 00 to 90)
Azimuth	269	degrees	Channel 4 (Range 000 to 359)
SNR (C/No)	40	dB-Hz	Channel 4 (Range 00 to 99, null when not tracking)
Checksum	*7A		
<CR> <LF>			End of message termination

1. Depending on the number of satellites tracked multiple messages of GSV data may be required.

● RMC---Recommended Minimum Specific GNSS Data

Table 5.1-9 contains the values for the following example:

\$GPRMC,081728.00,A,2500.00032,N,12159.99914,E,0.003,,010206,,,A*76

Table 5.1-9 RMC Data Format

Name	Example	Units	Description
Message ID	\$GPRMC		RMC protocol header
UTC time	081728.00		hhmmss.sss
Status	A		A=data valid or V=data not valid
Latitude	2500.00032		ddmm.mmmm
N/S Indicator	N		N=north or S=south
Longitude	12159.99914		dddmm.mmmm
E/W Indicator	E		E=east or W=west
Speed over ground	0.003	knots	True
Course over ground		degrees	
Date	010206		ddmmyy
Magnetic variation		degrees	
Variation sense			E=east or W=west (Not shown)
Mode	A		N=no fix, A=autonomous, D=DGPS, E=DR
Checksum	*76		
<CR> <LF>			End of message termination

● VTG---Course Over Ground and Ground Speed

Table 5.1-10 contains the values for the following example:

\$GPVTG,,T,,M,0.003,N,0.006,K,A*26

Table 5.1-10 VTG Data Format

Name	Example	Units	Description
Message ID	\$GPVTG		VTG protocol header
Course over ground		degrees	Measured heading
Reference	T		True
Course over ground		degrees	Measured heading (Not shown)
Reference	M		Magnetic
Speed over ground	0.003	knots	Measured speed
Units	N		Knots
Speed over ground	0.006	km/hr	Measured speed
Units	K		Kilometer per hour
Mode	A		N=no fix, A=autonomous, D=DGPS, E=DR
Checksum	*26		
<CR> <LF>			End of message termination

● ZDA---Time and Date

Table 5.1-11 contains the values for the following example:

\$GPZDA,081727.00,01,02,2006,00,00*6A

Table 5.1-11 ZDA Data Format

Name	Example	Units	Description
Message ID	\$GPZDA		ZDA protocol header
UTC time	081727.00		hhmmss.ss
Day	01		01 to 31
Month	02		01 to 12
Year	2006		4 digit year
Local zone hour	00		Not supported (fixed to 00)
Local zone minutes	00		Not supported (fixed to 00)
Checksum	*6A		
<CR> <LF>			End of message termination

5.2 Proprietary NMEA input/output message

Please refer to the u-blox proprietary messages.

5.3 Examples to configure the GPS module

The GPS module can receive NMEA and UBX binary protocol at the same time so that users can directly issue UBX binary command to the GPS module. Please note that any configuration settings are stored in the battery-backed SRAM after sending the command of saving current configuration. Once the battery drains out, the default/factory settings will be applied.

5.3.1 Change update rate

The default (factory) update rate is 1 Hz. The following flow chart is an example to change update rate to 4 Hz.

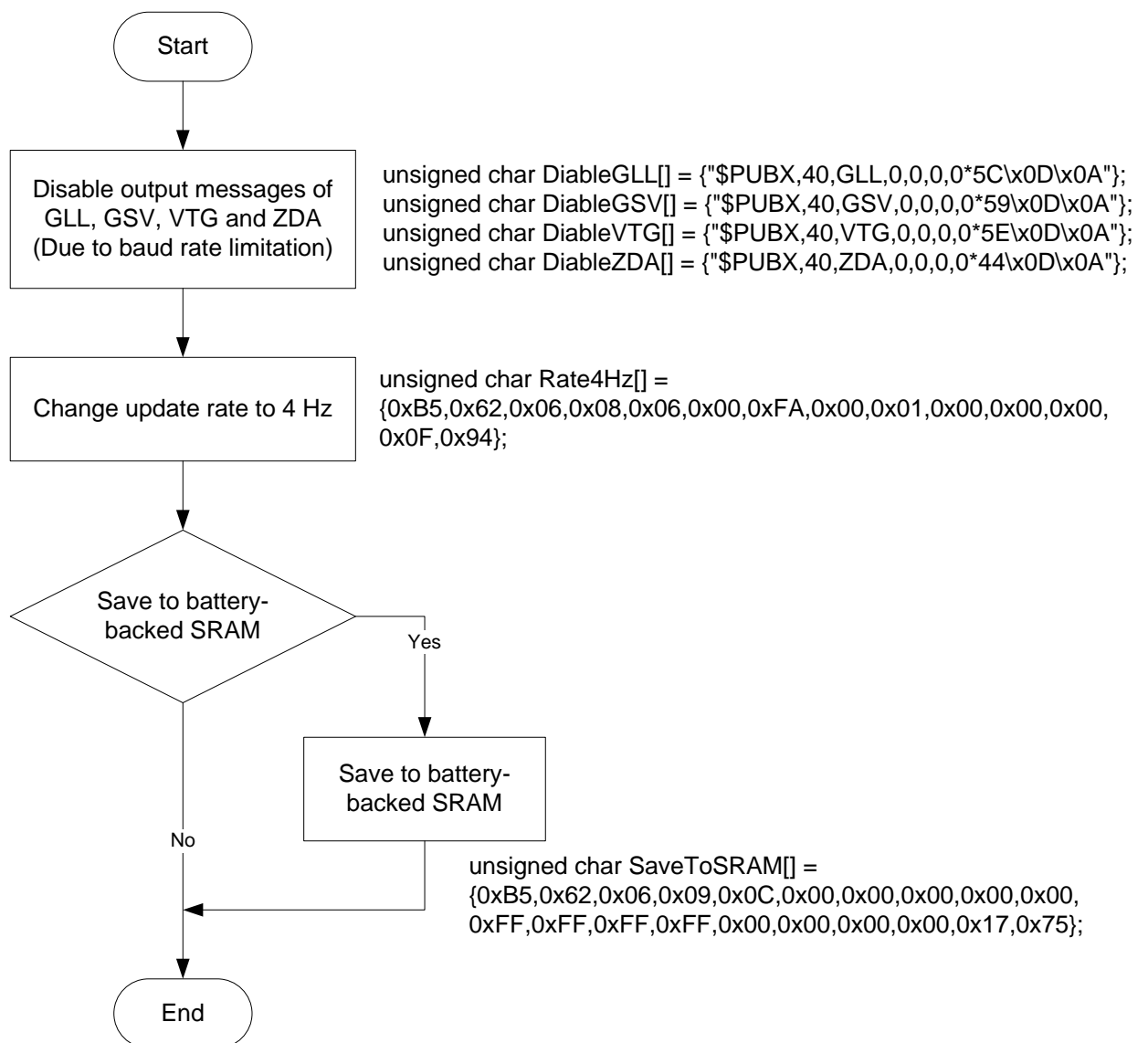

5.3.2 Change dynamic platform

The default (factory) dynamic platform is for automotive. The following flow chart is an example to change dynamic platform to for pedestrian.

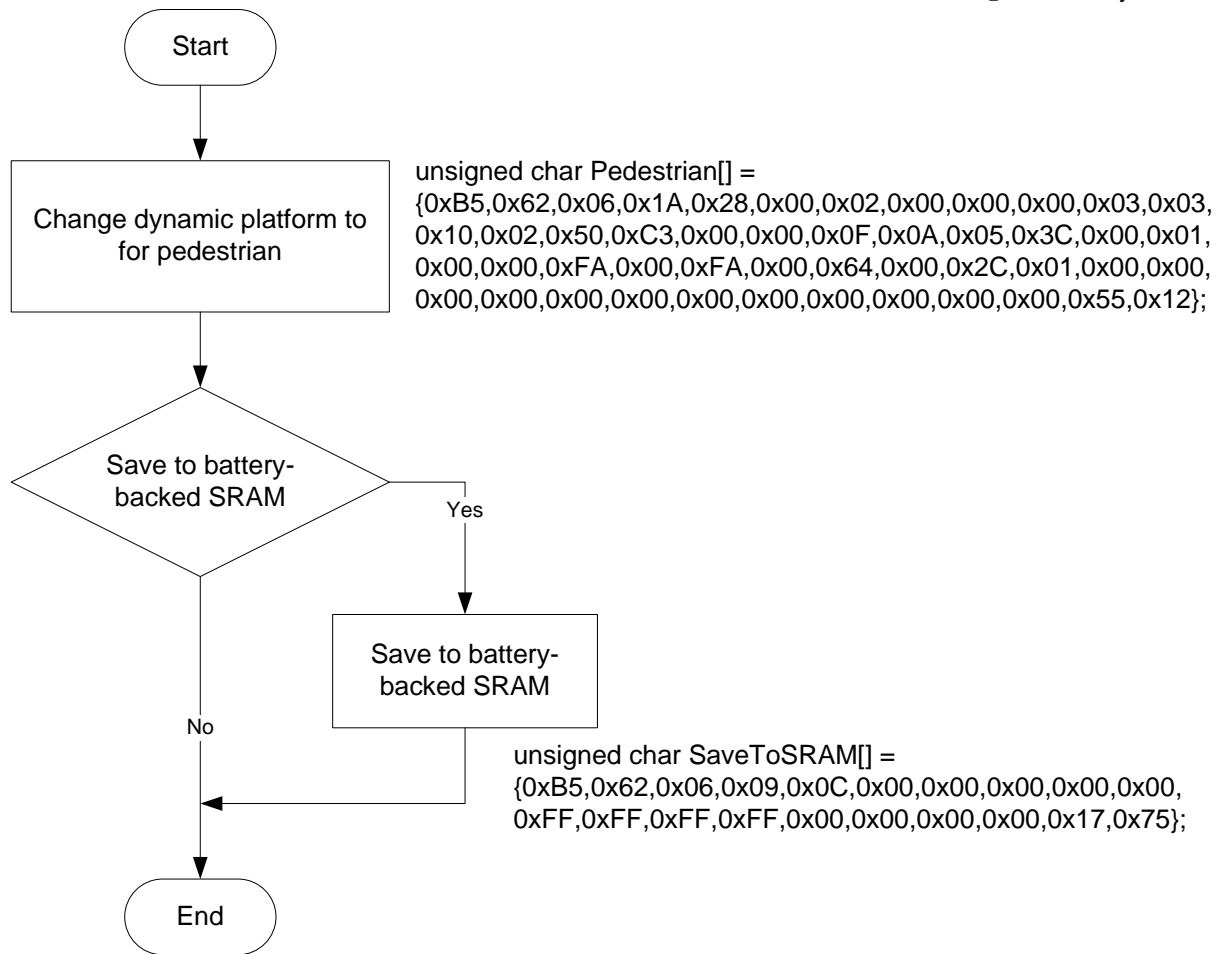

5.3.3 Change operation mode

The default (factory) operation mode is continuous mode. The following flow chart is an example to change operation mode to Fix Now Mode (FNM). In FNM mode, the GPS module automatically awakens every FXN period (it is 30 minutes in this example) to obtain a position fix, collect ephemeris (if needed), and calibrate the real-time clock (RTC) (if needed). This functionality allows a quick navigation solution to be obtained when the user requests it by sending a command (Position Request Command). Besides, the power consumption is extremely low (130uA in sleep state). Upon activation, it searches for up to the maximum acquisition time (it is 120 seconds in this example) to obtain a position fix. If a position fix is not obtained during that time, the GPS module deactivates until the maximum off time is reached (it is 10 minutes in this example).

Please add header with dummy data for any command when the GPS module is in sleep mode. This is required for wake-up in sleep mode. The dummy data in hexadecimal is “0xFF,0xFF,0xFF,0xFF,0xFF,0xFF,0xFF,0xFF”.

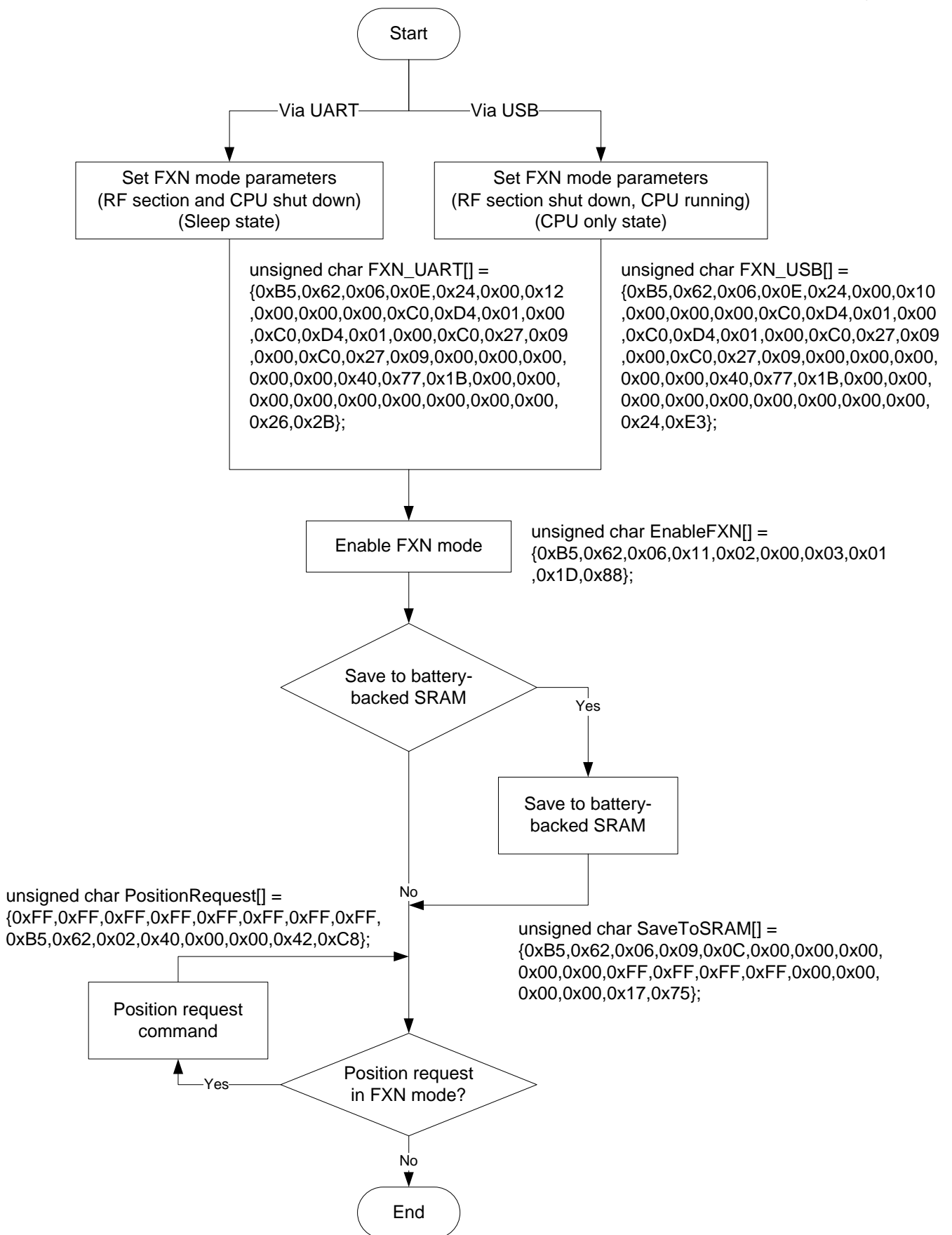

5.3.4 Revert to default configuration

The following flow chart is an example to revert the GPS module (including battery-backed SRAM) to default/factory configuration.

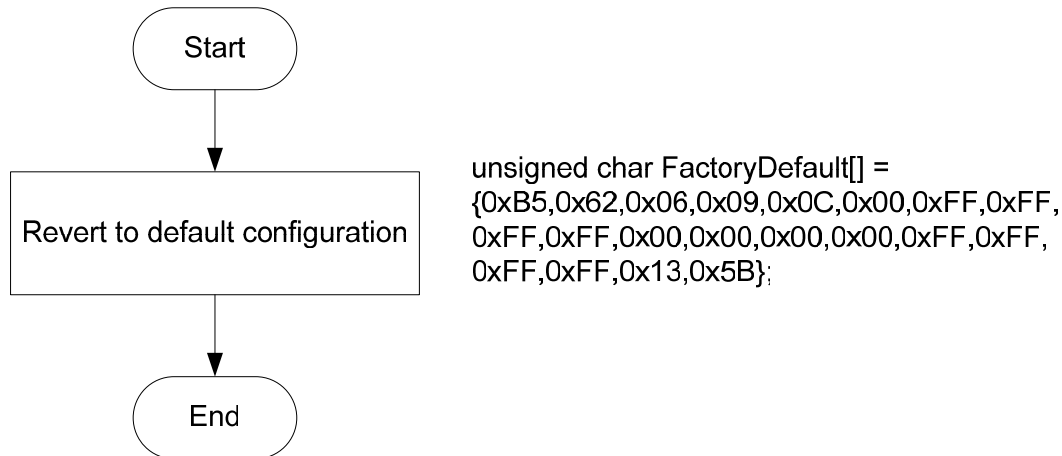

6 LED indicator

The red LED is an indicator of GPS positioning status. In continuous power mode, it flashes when the position is fixed. Otherwise it is off. The timing in detail is as below.

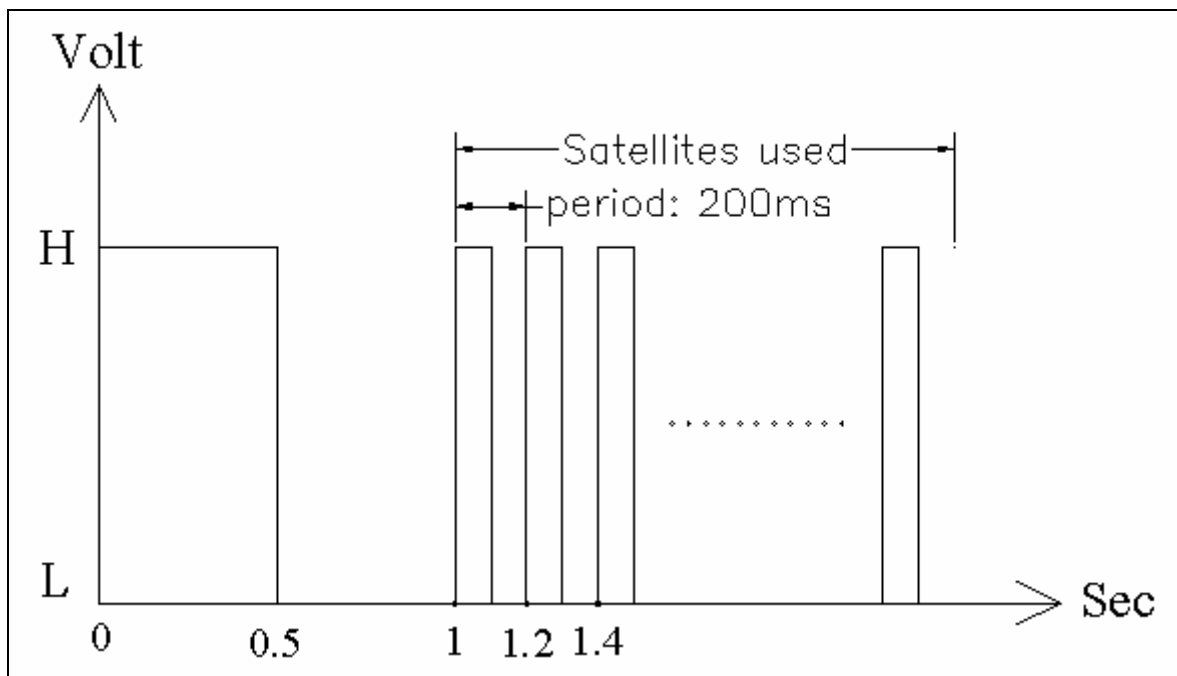

Fig. 6-1 shows output waveform when GPS position is fixed.

7 Pin assignment and descriptions

- **LS23060**

Pin #	Name	Type	Description
-------	------	------	-------------

1	VBUS	P	USB power input
2	D-		D- line
3	D+		D+ line
4	GND	P	Ground

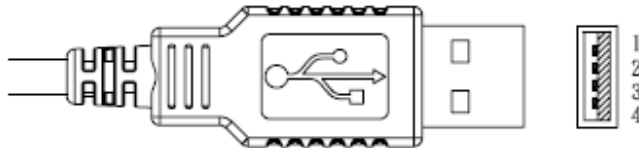

USB A-TYPE Plug

● **LS23062**

Pin #	Name	Type	Description
1	GND	P	Ground
2	VDD	P	Power input
3	NC		Not connect
4	RX	I	Data input (RS232 level)
5	TX	O	Data output (RS232 level)
6	NC		Not connect

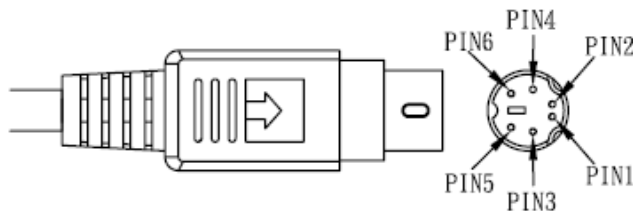

PS2 MALE

● **LS23063**

Pin #	Name	Type	Description
1	VDD	P	Power input
2	RX	I	Data input (RS232 level)
3	TX	O	Data output (RS232 level)
4	GND	P	Ground
5	NC		Not connect
6	NC		Not connect

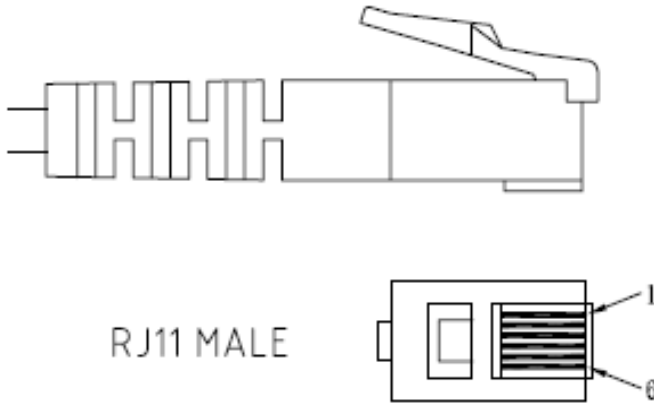

RJ11 MALE

● **LS23065**

Pin #	Name	Type	Description
1	VDD	P	Power input
2	GND	P	Ground
3	NC		Not connect
4	TX	O	Data output (RS232 level)
5	RX	I	Data input (RS232 level)
6	NC		Not connect

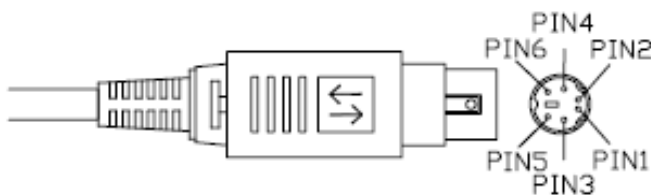

PS2 MALE
with lock

● **LS23066**

Pin #	Name	Type	Description
1	NC		Not connect
2	GND	P	Ground
3	RX	I	Data input (RS232 level)
4	TX	O	Data output (RS232 level)
5	VDD	P	Power input
6	NC		Not connect

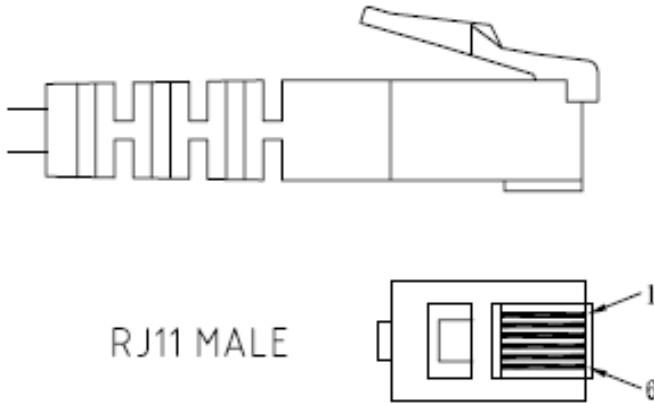

RJ11 MALE

8 DC & Temperature characteristics

8.1 Power consumption (continuous mode)

Parameter	Symbol	Product	Min.	Typ.	Max.	Units
Input voltage	VCC	LS23060	4.75	5	5.25	V
		LS23062	4	5	6	
		LS23063	4	5	6	
		LS23065	4	5	6	
		LS23066	4	5	6	
Input current	Icc	LS23060		49 ⁽¹⁾		mA
		LS23062		50 ⁽¹⁾		
		LS23063		50 ⁽¹⁾		
		LS23065		50 ⁽¹⁾		
		LS23066		50 ⁽¹⁾		

1. This is average value that is measured when position fix is available and input voltage is 5V.

8.2 Temperature characteristics

Parameter	Symbol	Min.	Typ.	Max.	Units
Operating Temperature	Topr	-30	-	85	°C
Storage Temperature	Tstg	-40	25	85	°C

9 Mechanical specification

● LS23060 (USB interface)

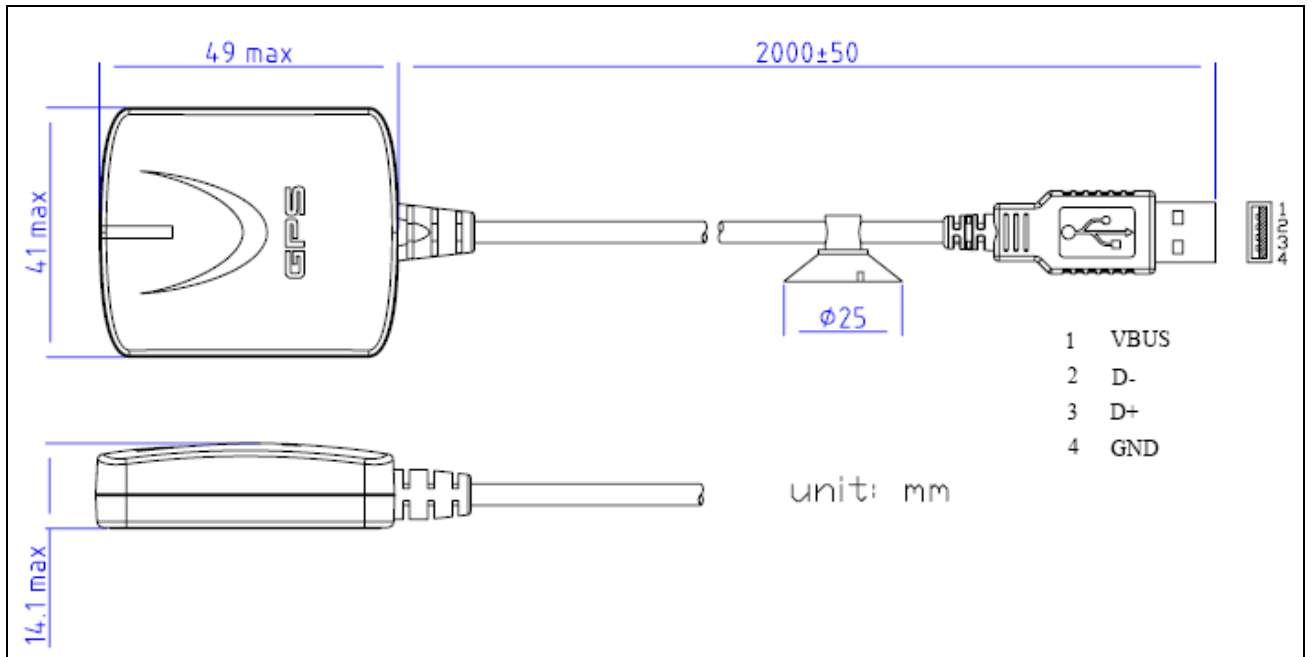

● LS23062 (RS232 interface)

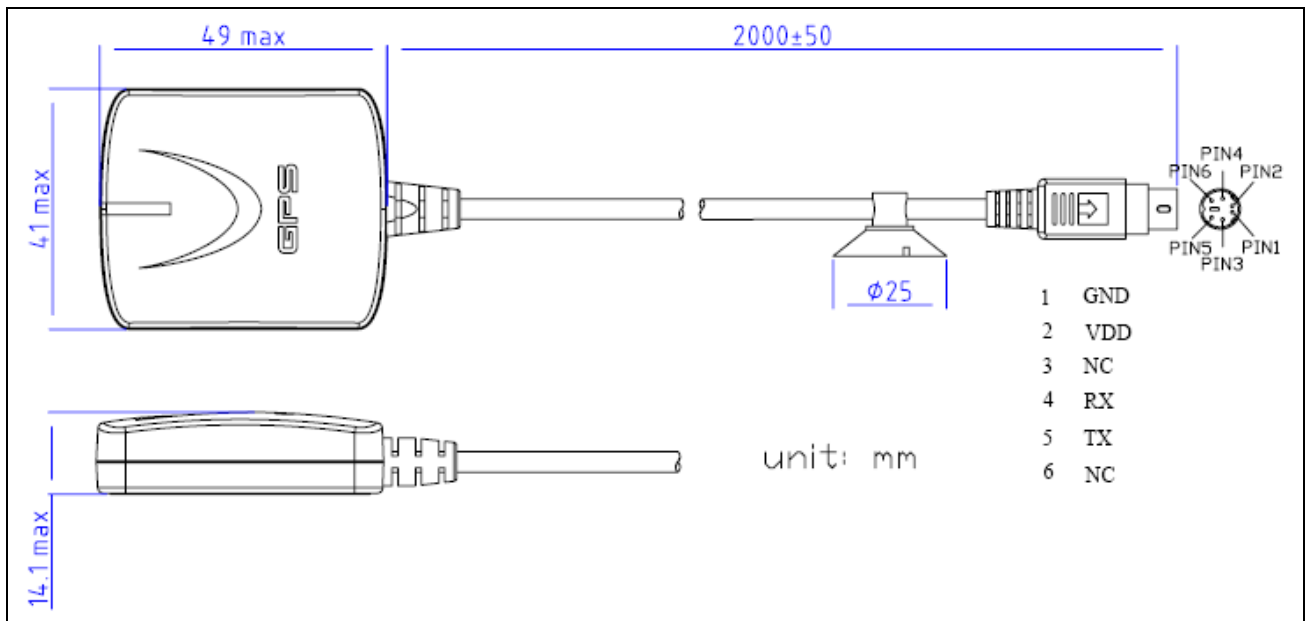

● **LS23063 (RS232 interface)**

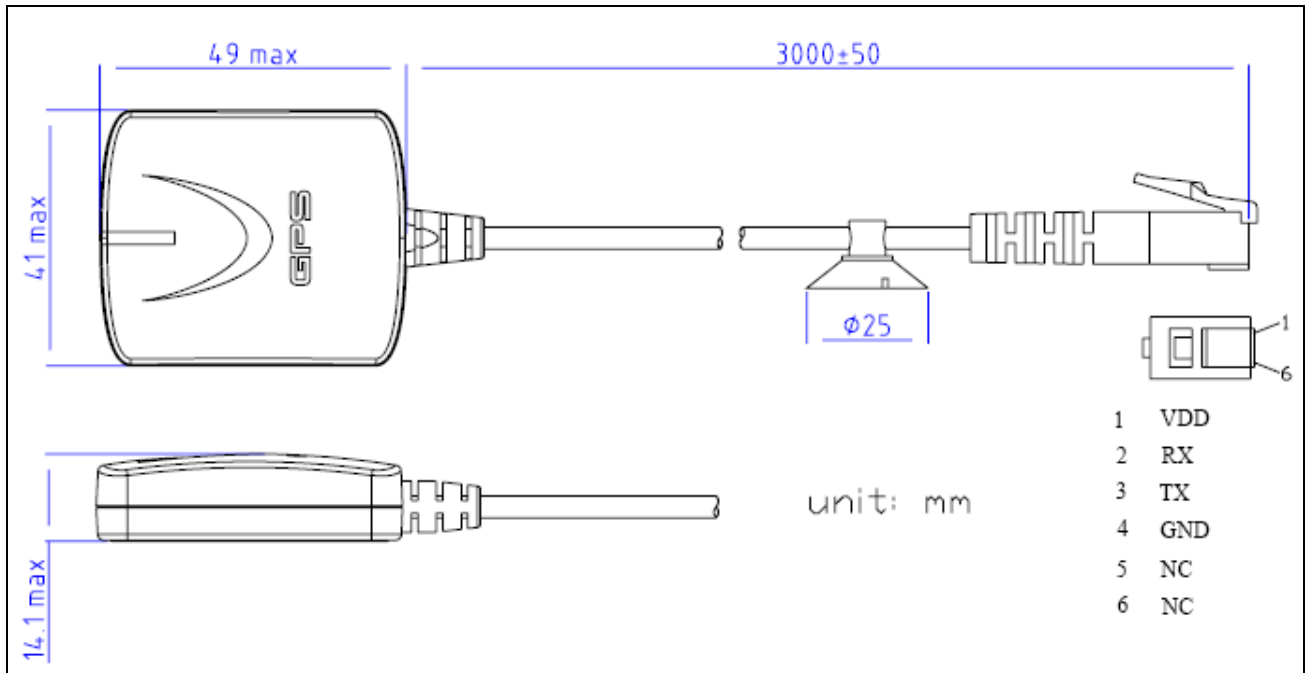

● **LS23065 (RS232 interface)**

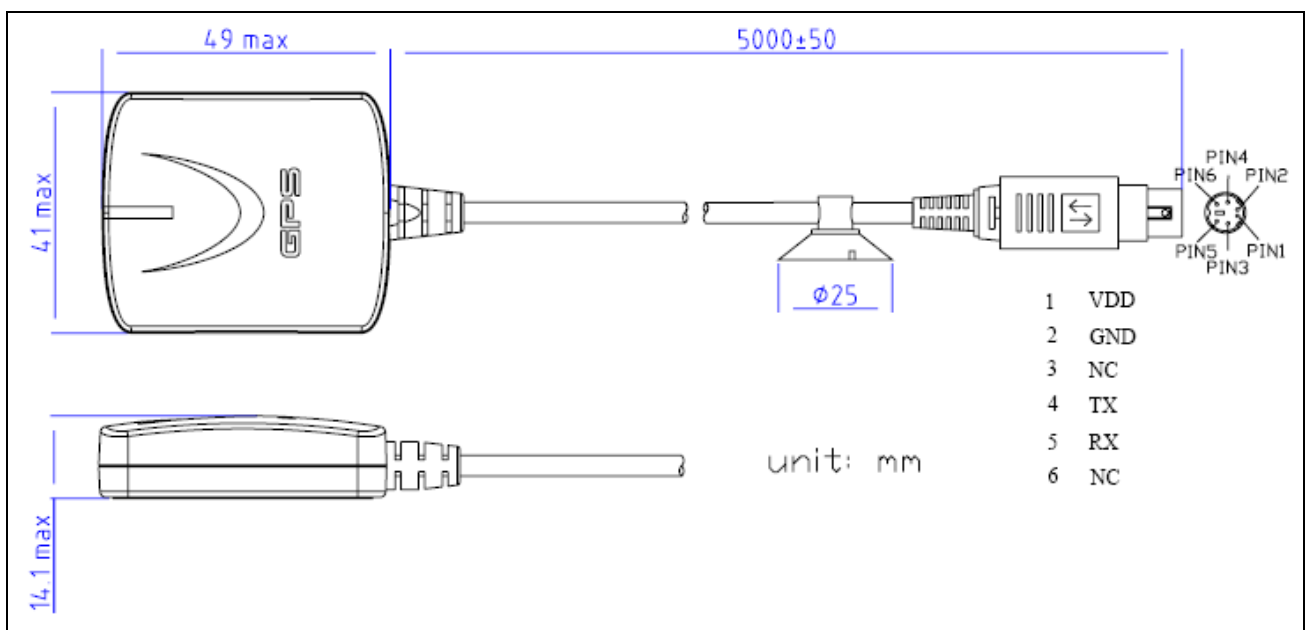

● **LS23066 (RS232 interface)**

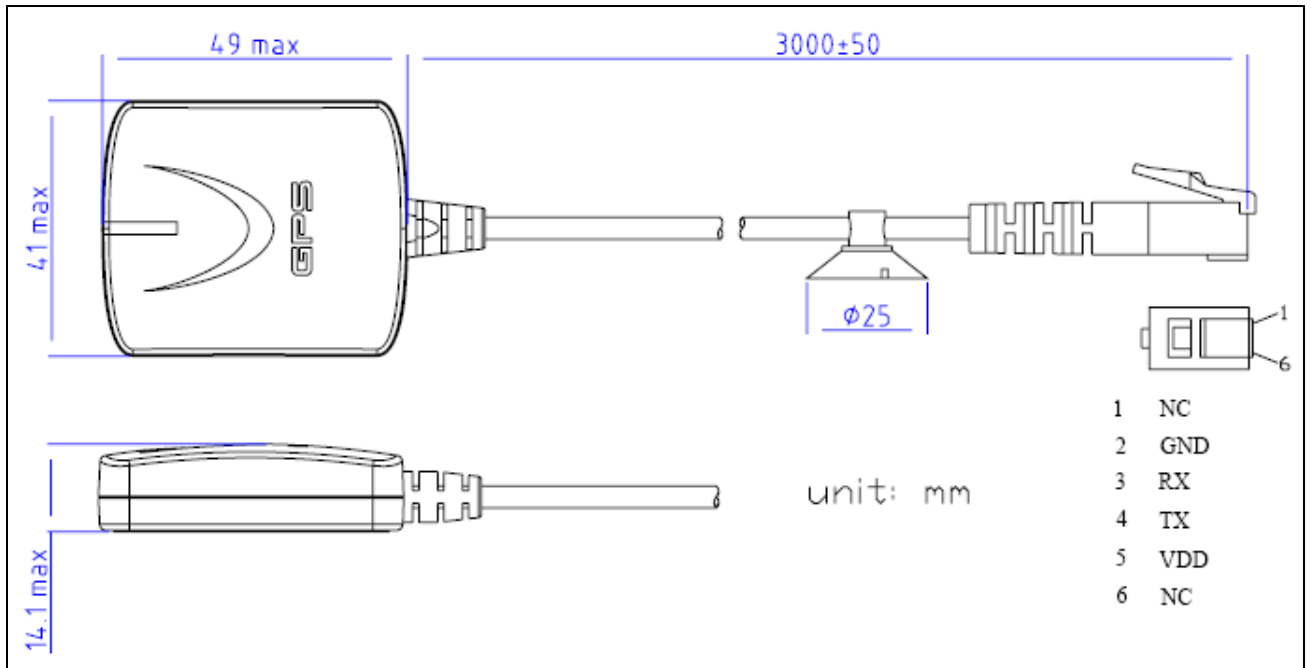

Document change list

Revision 1.0

- First release on Jan. 30, 2007.